



***DENAGO***

# **QUICKSTART GUIDE**

**CITY MODEL 1**



# ***DENAGO***

With over 100 years collectively in the bike industry, our team loves to share with you what we learned from riding, working in bike shops and working in the bike industry.

We are looking forward to you joining us for a ride..



**THANK YOU** and welcome to the Bike.com team.  
We value and appreciate you and your choice.

If there is anything you need, please reach out and  
let us know how we can help.

Email: [cs@bike.com](mailto:cs@bike.com)  
Call Us: 877-755-2453 (BIKE)



## **ALWAYS WEAR A HELMET**

Please make sure you read, understand and follow the instructions in the **quickstart guide** as eBikes are new to most riders.

For more information, please visit:  
**[www.Bike.com/support](http://www.Bike.com/support)**



# ***DENAGO***

## **CITY 1**



## WHAT'S IN THE BOX

The following accessories are included with your 90% pre-assembled Denago bike.

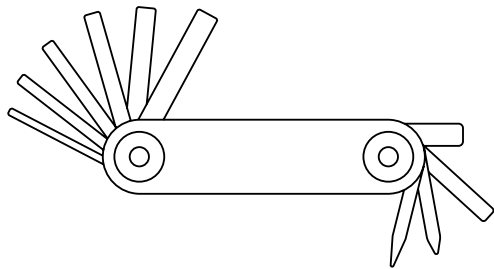

Multi Tool

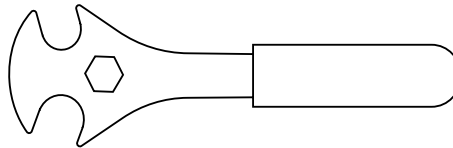

Pedal / Wheel Wrench



Bicycle grease packet

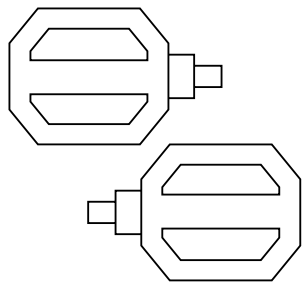

Pedal

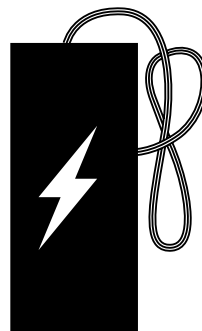

Battery Charger

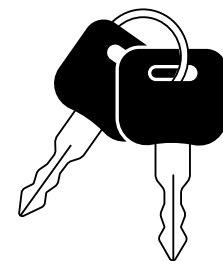

Battery Keys

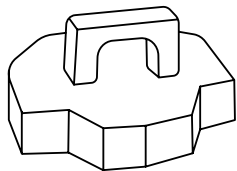

Battery Connector Protector



## **Your Denago bike is 90% assembled**

The **quickstart guide** will assist you in completing the assembly. By following the directions, you will be able to get outside and start riding your new Denago eBike in less than 30 minutes.

**If you are not comfortable or confident, please take your bike to your local shop and ask for assistance.**

# GETTING STARTED





Unpack and Unwrap your **DENAGO** eBike



# LAY OUT THE PARTS AND TOOLS

We'd like to make your assembly process a bit easier.  
So we made a Parts & Tools layout inside the box.  
Please lay Parts & Tools into each area.

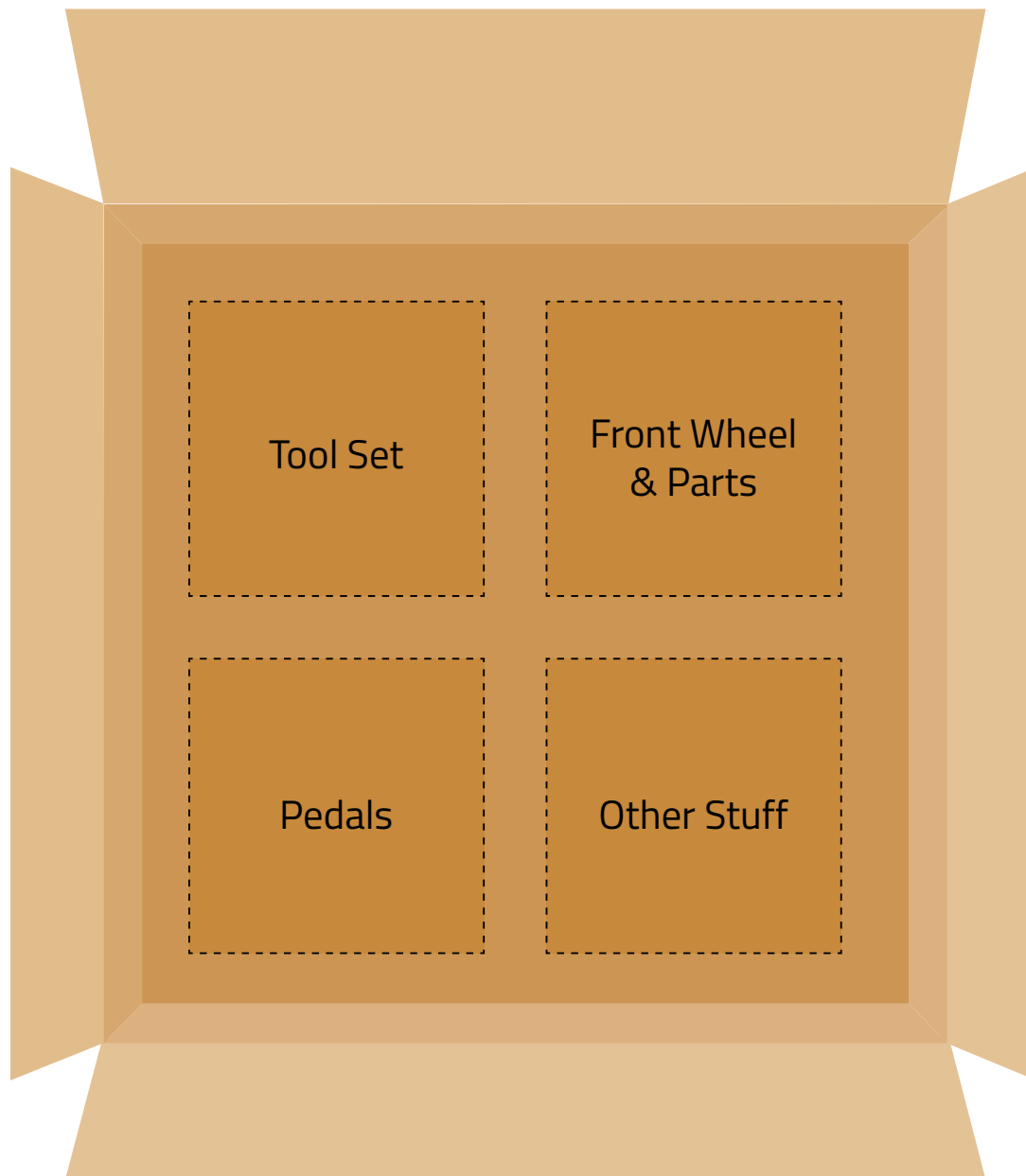

# **ASSEMBLY STEPS**

**1. HANDLEBAR**

**2. SEAT**

**3. FRONT WHEEL & BRAKE**

**4. PEDALS**

**5. ADJUSTMENTS**

**6. MONITOR**

# 1. HANDLEBAR

## HANDLEBAR COMPONENTS HAS BEEN PRE-ASSEMBLED

Please tighten and secure all bolts

You will use the 5mm allen key on the multi tool for these steps.



**1.** Unscrew bolt and remove cap, bolt, and sleeve. Set these 3 items aside. You will not need them moving forward. Leave all spacers in place



**2.** Remove handlebar from packaging. Using the 5mm allen wrench loosen all 4 bolts counterclockwise. Do NOT remove bolts completely - It only needs to be loosened to rotate stem/handlebar



**3.** Rotate handlebar - CAUTION - ensure cables are in position as shown



**4.** Rotate handlebar to the position where logo is with in the center of the stem. In SECTION 5 Adjustments you can fine tune the position of the handlebars for safety and comfort.



**5.** Using 5mm allen wrench tighten and secure all four (4) bolts.



**6.** Place stem on steerer tube and tighten the internal bolt on the top of stem to secure to the steer tube



**7.** Place stem onto the head tube.  
Align stem to the center position



**8.** Tighten and secure bolts on  
bottom of stem



**9.** Add Top Cap to stem bolt



**10.** Upon final assembly, revisit this  
step to confirm alignment with stem  
and front wheel

## 1. HANDLEBAR

You will need the 3mm allen key on the multi tool to install.



**Monitor Installation.** Remove bolts and place monitor on handlebar with a bracket on each side of the stem. Make sure that you can clearly see the monitor while sitting the the seat. Insert the bolts- tighten and secure.

You will need the +/phillips screw driver in the multi tool to install.



**Front Reflector Installation.** Remove the screw and place bracket over the handlebar on the left side closest to the monitor, if you are sitting on the seat. Tighten and Secure the screw.



**Bell Installation.** Remove the screw and place bracket over the handlebar on the right side closest to the brake lever, if you are sitting on the seat. Tighten and Secure the screw.

## THE SEAT WAS PRE-ASSEMBLED

## 2. SEAT



1. Install Rear Reflector (Red) to Seat Post



2. Apply grease inside Seat Tube



3. Place Seat Post inside Seat Tube  
- Insert past MIN Insertion Marking



4. Adjust the seat height. Clamp secure/  
tighten the quick release clamp



### CAUTION

Make sure seat post is inserted to at least minimum insertion markings are **NOT** visible

### 3. FRONT WHEEL & FRONT BRAKE

### YOUR BIKE HAS A BOLT ON MECHANISM



**1.** Remove Packing Block from disc brake caliper – Do Not Throw Away – Re-install Packing Block whenever you remove your front wheel



**2.** Position the front wheel so it's centered between the front fork legs with the axle resting inside the fork drop outs



**3.** Align the disc brake rotor so it is centered in the slot of the brake caliper



**4.** Tighten one axle nut part way then tighten the other nut, repeat until both sides are tightened securely. Be sure that the wheel is centered between the fork legs

### CAUTION

Tighten nuts securely to the fork dropouts







# WARNING

Do **NOT** touch the brake rotor, especially while in motion. Be **CAUTIOUS** and do not allow oils to be applied or added to the **DISC/ROTOR**. This can cause squeaking and decrease braking performance.

Improper installation of the front wheel and or handlebar stem can cause loss of control, accidents, serious injury or death. Check regularly that the front wheel and handlebar stem are **ALWAYS** properly secure and in good working condition.

## 4. PEDALS



1. Drive Side of Bike select R-Right pedal
2. Apply grease to pedal threads
3. Insert Pedal into Crank/Drive side and start to turn CLOCKWISE.
4. Once hand tight apply pedal wrench to pedal and tighten and secure.



1. NON Drive Side of Bike select L-Left pedal
2. Apply grease to pedal threads
3. Insert Pedal into Crank Arm/NON- Drive side and start to turn COUNTER CLOCKWISE.
4. Once hand tight apply pedal wrench to pedal and tighten and secure.



Apply grease to threads on both Left and Right Pedal.

**MATCH PEDAL and CRANK ARM CAREFULLY**

Right pedal is applied to drive side/side with crank and gears and threads/twist on CLOCKWISE  
Left pedal is applied on NON-DRIVE side/side with disk rotors and twist COUNTERCLOCKWISE

**USE PEDAL WRENCH AND CONFIRM PEDALS ARE TIGHTENED AND SECURE**

Check frequently



Please confirm **STEM AND FRONT WHEEL** are in alignment.



## 6. MONITOR

The monitor is connected in a number of ways to your eBike. It interfaces with the HMI to adjust your PAS levels, advises if you have a problem with your brakes and also tracks a number of great features. Like speed, distance, MAX speed, battery level etc.

The following will show you how to confirm and make needed adjustments.



**STEP 1** – Press and hold **M (MODE)** button until screen turns to either MAX speed or AVE speed.

**STEP 2** – Press and hold **+ - (UP/Down)**

simultaneously for 2-4 seconds until screen flashes and goes to setting interface. You have 4 settings, use the + - to toggle thru each screen and the M to move to the next setting.



**SETTING 1 – inCH:** Wheel size setting.  
Your Denago City 1.0 is 27.5.



**SETTING 3 – BL:** This is screen brightness.  
You have 3 levels.



**SETTING 2 – LS:** Limited Speed.  
This is your max speed setting.



**SETTING 4 – unit:** This is the speed and distance setting MPH or KPH.

Your monitor has many unique settings. The following will share how to use the PASSCODE SECURITY settings and well as turn this feature on and off.



**STEP 1** – Press **M MODE** button until screen turns to either MAX speed or AVE speed.

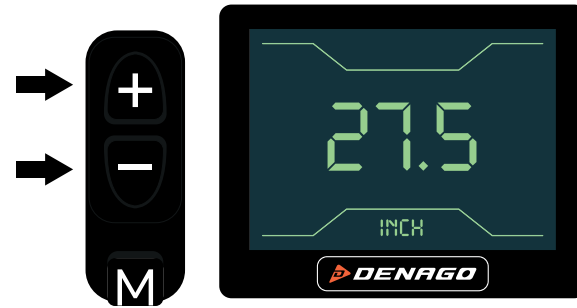

**STEP 2** – Press **+ - (UP/Down)** simultaneously for 2-4 seconds until screen flashes and goes to setting interface. You have 4 settings.

Use the **+ -** to toggle thru each screen and the **M** to move to the next setting  
Scroll through the settings until you get to **PASSCODE** - at this point you can either set your code.

**NOTE** please write this down and remember this. Your monitor can be reprogrammed but it will require speaking to an agent.  
If you do not want this feature simply turn it off. You do this by moving the **+ -** to your desired preference. Press the **M** button to return to the main screen.

## 6. MONITOR

The following instructions will outline how you set the MAX Speed in Pedal Assist (PAS) level 5. Once this is set it will adjust each of the other levels by a preset percentage.



**STEP 0** – Locate the HMI - Human Machine Interface.

**STEP 1** – Press **M (MODE)** button to engage screen.

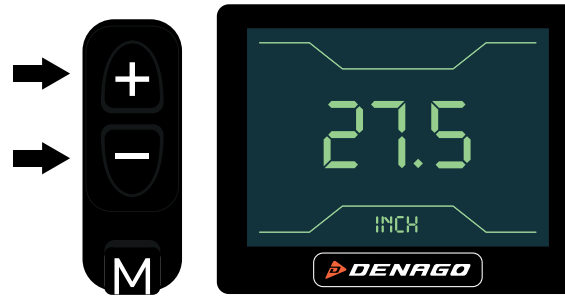

**STEP 2** – Press **+ - (UP/Down)** simultaneously for 2-4 seconds until screen flashes and goes to setting interface.

**STEP 3** – First screen to pop up is wheel size.

Press **M (MODE)** to go to next screen.



**STEP 4** – Limited Speed mode - (**LS**) this is where you can adjust MAX speed.

Use the **+ - (UP/Down)** to adjust MAX limit.

Your range is **28 - 11 mph** as the lowest limit.



**STEP 5** – Press **M (MODE)** for 2 seconds to return to main screen. You are ready to ride.

Denago City 1.0 PAS (Pedal Assist System) comes with the ability to set your MAX speed while also adjusting your PAS level speeds.

**Custom Pedal Assist Settings** - The rider is able to adjust the MAX speed setting with 18 micro adjustments

- 28mph MAX down to 11mph
- With adjustment it will proportional adjust each of the other PAS levels accordingly (chart included)
- Adjustment made with 4 easy steps
- Easy to do anywhere
- Allows for better rider comfort, control, confidence, and safety
- Assist in better pedal engagement when rider preferred settings are achieved

MPH	PAS1	PAS2	PAS3	PAS4	PAS5
28	16.8	19.6	22.4	25.2	28
27	16.2	18.9	21.6	24.3	27
26	15.6	18.2	20.8	23.4	26
25	15	17.5	20	22.5	25
24	14.4	16.8	19.2	21.6	24
23	13.8	16.1	18.4	20.7	23
22	13.2	15.4	17.6	19.8	22
21	12.6	14.7	16.8	18.9	21
20	12	14	16	18	20
19	11.4	13.3	15.2	17.1	19
18	10.8	12.6	14.4	16.2	18
17	10.2	11.9	13.6	15.3	17
16	9.6	11.2	12.8	14.4	16
15	9.1	10.5	12	13.5	15
14	8.4	9.8	11.2	12.6	14
13	7.8	9.1	10.4	11.7	13
12	7.2	8.4	9.6	10.8	12
11	6.6	7.7	8.8	9.9	11

# SOME OTHER IMPORTANT THINGS

Owner's Manual and more comprehensive details are available online.  
Please go to [WWW.BIKE.COM/SUPPORT](http://WWW.BIKE.COM/SUPPORT) for content and video support

You're almost finished, but now is the time for the final adjustments and safety check.  
Then you will be ready for a test ride.

You will be making safety, fit and comfort adjustments.

## 1. Handlebar

Alignment and tighten and secure all bolts on stem and handlebar.  
Confirm stem and front wheel are in alignment.

## 2. Brake Check

Confirm brakes work properly- Physical check Front and Rear Brakes

## 3. Wheel Check

Confirm axle nuts are tight  
Check tire wear, bead line, and air pressure

## 4. Seat Height Adjustment

Confirm comfort and proper leg extension and seat clamp is secure

**IF YOU HAVE ANY QUESTIONS OR CONCERNS,  
PLEASE CONTACT US OR SEEK PROFESSIONAL SERVICE  
FROM YOUR LOCAL BIKE SHOP**





## Getting Ready for your First Ride and Each Future Ride

1. Confirm you battery is fully charged and installed correctly.
  - a. Your monitor will not turn on if you are charging your battery  
To Turn on the Monitor Press the M button on the HMI.
  - b. The key is only to secure and remove the battery. It is not an ON/OFF key.

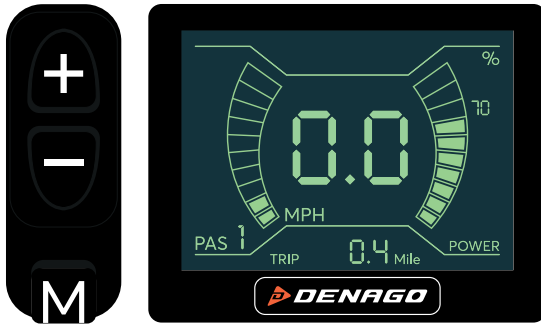

2. Check you tire pressure
3. Check your wheels are secure and mounted correctly
4. Check you brakes for function
5. Check your wheels to insure true
6. Go thru and check all bolts for being tight and secure.

## Your Ready to Go

Always wear a helmet and be safe

Standing over the bike you have the **HMI** (Human Machine Interface) controller on the left side. It has **+** **-** and **M** button  
Press the **M** button until the monitor/display turns on.

Check the PAS setting - Ideally you want to start in **PAS0** or **PAS1**.

See Speed Adjustment to help find your most comfortable setting.

**YOU ARE READY to RIDE. ENJOY!**

## UNINSTALLING THE BATTERY

1. Turn Key Until you hear CLICK
2. Once the battery clicks it will move out
3. Lifting battery out
4. Lift battery UP and remove
5. Frame area is clear of battery. Check connectors toward the bottom of battery cavity

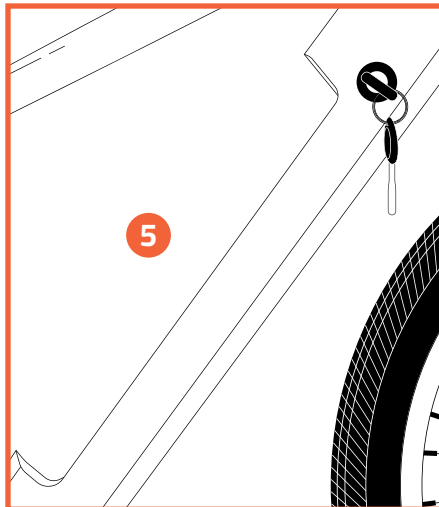
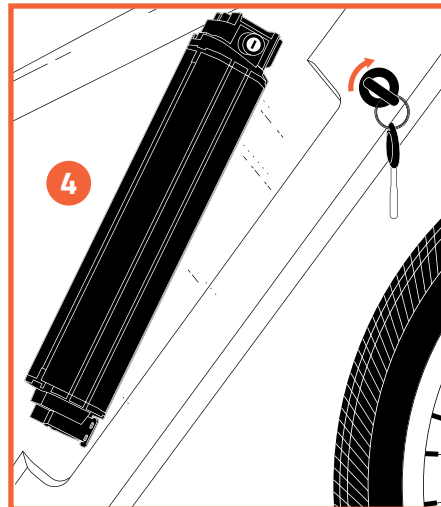
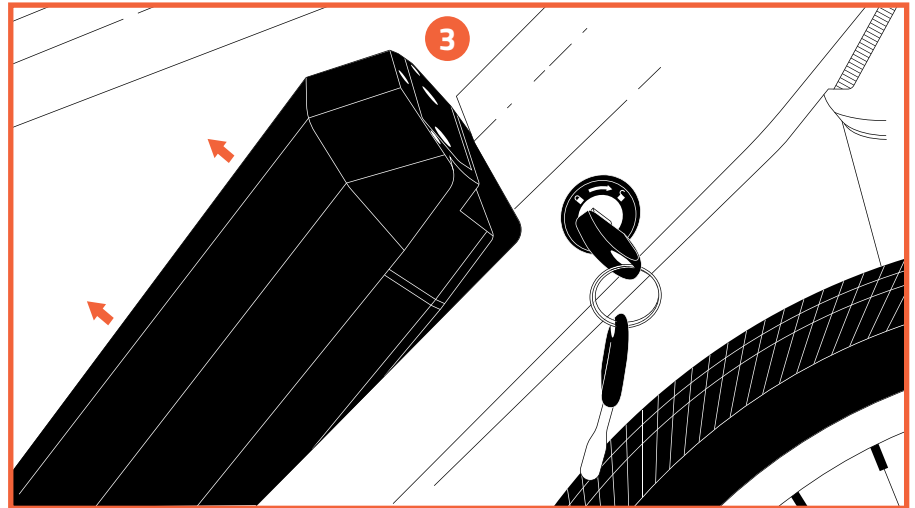
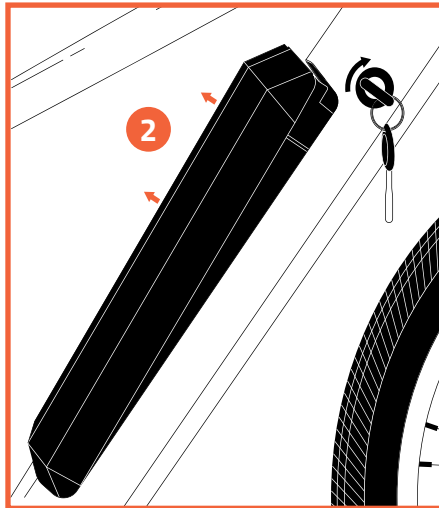
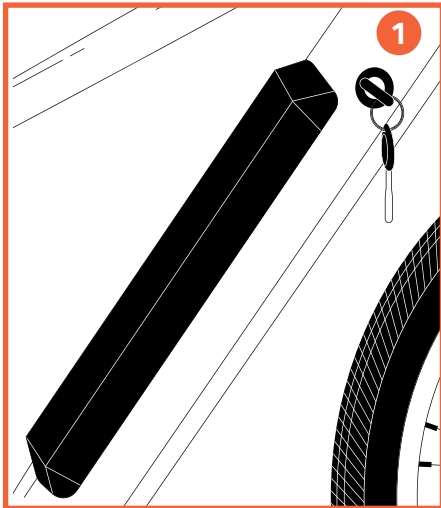

## REINSTALLING THE BATTERY

1. With Open Battery Cavity, check connectors.  
Key is not needed to install battery
2. Place bottom of battery into frame cavity  
and slide down to connect

3. Battery should be inside cavity  
and press closed to hear a click
4. Key is not needed to install battery but  
if in place remove and Enjoy the Ride

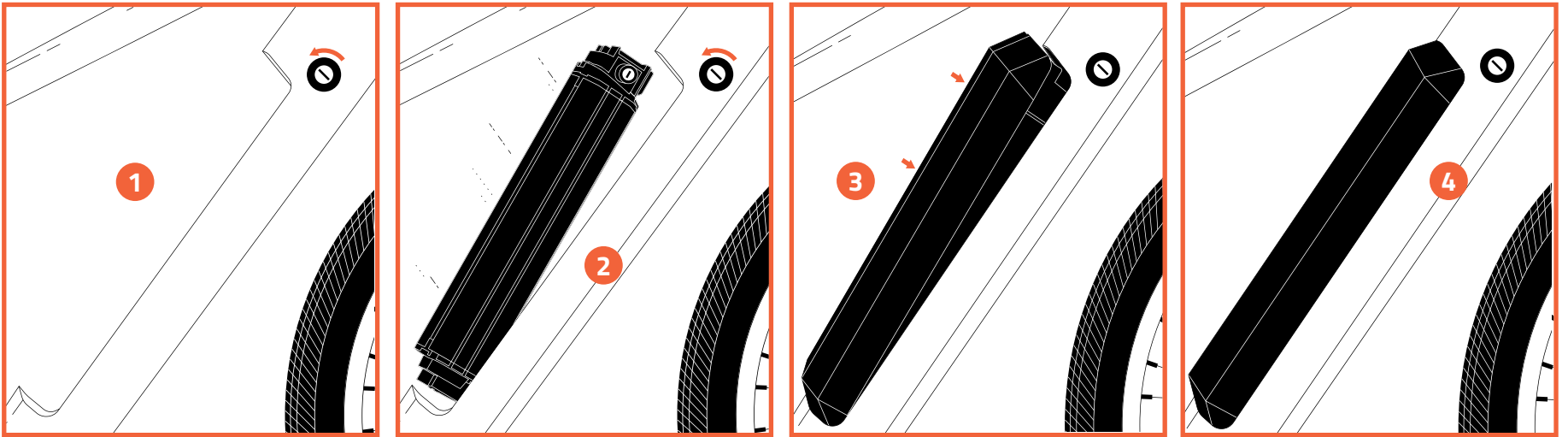

## BATTERY DETAILS

You can charge your battery while it is in your bike.

1. Plug Charger into the PORT on the Battery
2. Plug Charger into the WALL OUTLET (110V)



Only use factory supplied battery and battery charger. Failure to do so could result in damage, fire, serious injury or death.

Keep battery and charger away from children.

**DO NOT** ever cover the battery or charger. This could cause overheating and potential fire.

**DO NOT** open the battery housing. You will void all warranties and potential for serious injury and or death could occur.



# **INTENDED USE AND SAFETY CHECK**

## **INTENDED USE**

Your bike is intended to be ridden on paved roads. Please always wear a helmet and follow all local and common-sense safety. Perform a safety check before and after EACH ride.

## **SAFETY CHECK**

For your safety, please do the following inspection before and after each ride.

If you discover any concerns with your bike, please seek professional service or contact us at **cs@bike.com** or **877-755-2453 (BIKE)** to help resolve any issues.

- Make sure your battery is at FULL Charge.
- Do a Brake, Wheel and Tire CHECK- Both Front and Rear.
- Check tire inflation, make sure there are no foreign objects or bulges in tires.
- Spin Wheels freely and confirm NO brake rub or wobbles.
- Confirm Wheels are tightened and secured.
- Do a BRAKE CHECK - Both Front and Rear.
  - Lift wheel off ground and spin wheel.
  - Squeeze brake to insure no rub and immediate stop.
- Check Gears by lifting rear wheel, rotating crank and shifting gears. Make sure gears move smoothly and chain is properly lubricated.
- Know and understand how all aspects of the eBike components work and be sure to understand how to accelerate and control the bike along with braking.  
If needed adjust the payload for even balance.
- If you notice any cracks, dents, or abnormal issues please seek immediate professional support.
- Know your area, the local laws and the terrain you are riding on.

**NOTE:** If wet or at dawn, dusk, or dark, your riding will be impaired. Do not ride or ride with more caution. You will need to plan for extended braking and possible road differences. Be sure to be visible with lights and safety gear.

**RIDE** with **CAUTION** and **RIDE** with **SAFETY**. Always wear a helmet.

If have any issues above or any concerns, please seek immediate professional support prior to riding your bike.





**Warranty Information  
Owner's Manual  
How-to Videos  
and more info**

Available at [www.Bike.com/support](http://www.Bike.com/support)

*If you need any help,  
please give us a call **877-755-2453 (bike)**  
or email [cs@bike.com](mailto:cs@bike.com)*

***Bike.com***