

# EBIKE OWNER'S MANUAL

FAT MODEL 1 • VERSION 1



**DEWILLO**

## **IMPORTANT:**

This manual contains important safety, performance, and service information. Read it before you take the first ride on your new eBike and keep it for reference.

Additional safety, performance, and service information for specific components such as suspension or pedals on your eBike, or for accessories such as helmets or lights that you purchase, may also be available. Make sure that your dealer has given you all the manufacturers' literature that was included with your eBike or accessories. In case of a conflict between the instructions in this manual and information provided by a component manufacturer, always follow the component manufacturer's instructions.

If you have any questions or do not understand something, take responsibility for your safety and consult with **BIKE.com** at [cs@bike.com](mailto:cs@bike.com) or call at **1-(877)-755-2453(BIKE)** or visit your dealer or the eBikes manufacturer.

## **NOTE:**

This manual is not intended as a comprehensive use, service, repair, or maintenance manual. Please contact **BIKE.com** at [cs@bike.com](mailto:cs@bike.com) or call at **1-(877)-755-2453(BIKE)** or see your dealer for all service, repair, or maintenance. Your dealer may also be able to refer you to classes, clinics, or books on eBike use, service, repair, or maintenance.

# Contents



<b>GENERAL WARNING</b>	<b>p. 4</b>	1. Front wheel secondary retention device	p. 24-25
<b>A special note to parents</b>	<b>p. 5</b>	2. Wheels with cam action systems	p. 26
<b>1. First</b>	<b>p. 6-9</b>	3. Removing and installing wheel	p. 27-30
A. eBike fit	p. 6	B. Seat post cam action clamp	p. 30-31
B. Safety first	p. 6	C. Brakes	p. 31-33
C. Anatomy of Your Bike	p. 7	D. Shifting gears	p. 34-36
D. Mechanical Safety Check	p. 7-9	E. Pedals	p. 37-38
E. First ride	p. 9	F. eBike Suspension	p. 38-39
<b>2. Safety</b>	<b>p. 10-16</b>	G. Tires and Tubes	p. 39-41
A. The Basics	p. 10	H. eBike Components	p. 42-51
B. Riding Safety	p. 11	1. Battery	p. 42-45
C. Off Road Safety	p. 12	2. Motor	p. 45
D. Wet Weather Riding	p. 12	3. Throttle	p. 46
E. Night Riding	p. 13-14	4. Monitor	p. 46-50
F. Extreme, stunt or competition riding	p. 14-15	5. Harness	p. 51
G. Changing Components or Adding Accessories	p. 15	6. Riding Range of eBike	p. 51
H. E-Components	p. 16	<b>5. Service</b>	<b>p. 52-80</b>
<b>3. Fit</b>	<b>p. 17-22</b>	A. Service Intervals	p. 53-55
A. Stand over height	p. 17	B. If your eBike sustains an impact	p. 55
B. Saddle position	p. 18-20	<b>Appendix A: Teaching Your Child the Rules</b>	<b>p. 56-58</b>
C. Handlebar height and angle	p. 21-22	<b>Appendix B: Intended Use</b>	<b>p. 59-67</b>
D. Control position adjustments	p. 22	<b>Appendix C: Lifespan of your eBike and its components</b>	<b>p. 68-75</b>
E. Brake reach	p. 22	<b>Appendix D Fastener Torque Specification</b>	<b>p. 76-78</b>
<b>4. Tech</b>	<b>p. 23-49</b>	<b>Appendix E Trouble Shooting-BIKE</b>	<b>p. 79</b>
A. Wheels	p. 23	<b>Appendix F Trouble Shooting-Monitor</b>	<b>p. 80</b>
		<b>Getting Ready for your First Ride</b>	<b>p. 81</b>

## GENERAL WARNING:

Like any sport, bicycling involves risk of injury and damage. By choosing to ride a eBike, you assume the responsibility for that risk, so you need to know — and to practice — the rules of safe and responsible riding and of proper use and maintenance.

Proper use and maintenance of your eBike reduces risk of injury.

This Manual contains many “Warnings” and “Cautions” concerning the consequences of failure to maintain or inspect your eBike and of failure to follow safe cycling practices.

- The combination of the  safety alert symbol and the word **WARNING** indicates a potentially hazardous situation which, if not avoided, could result in serious injury or death.
- The combination of the  safety alert symbol and the word **CAUTION** indicates a potentially hazardous situation which, if not avoided, may result in minor or moderate injury, or is an alert against unsafe practices.
- The word **CAUTION** used without the safety alert symbol indicates a situation which, if not avoided, could result in serious damage to the eBike or the voiding of your warranty.

Many of the Warnings and Cautions say, “You may lose control and fall”. Because any fall can result in serious injury or even death, we do not always repeat the warning of possible injury or death.

Because it is impossible to anticipate every situation or condition that can occur while riding, this Manual makes no representation about the safe use of the eBike under all conditions. There are risks associated with the use of any eBike which cannot be predicted or avoided, and which are the sole responsibility of the rider.

## A SPECIAL NOTE FOR PARENTS:

**⚠️ WARNING: This manual covers both Adult and Juvenile, BMX and other types of youth-sized eBikes. And your child may be sold or may ride an adult-sized eBike as well.**

*As a parent or guardian, you are responsible for the activities and safety of your minor child, and that includes making sure that the eBike is properly fitted to the child; that it is in good repair and safe operating condition; that you and your child have learned and understand the safe operation of the eBike; and that you and your child have learned, understand and obey not only the applicable local motor vehicle, eBike and traffic laws, but also the common sense rules of safe and responsible bicycling. As a parent, you should read this manual, as well as review its warnings and the eBikes functions and operating procedures with your child, before letting your child ride the eBike.*

**⚠️ WARNING: Make sure that your child always wears an approved bike helmet when riding; but also make sure that your child understands that an eBike helmet is for bicycling only and must be removed when not riding. A helmet must not be worn while playing, in play areas, on playground equipment, while climbing trees, or at any time while not riding a eBike. Failure to follow this warning could result in serious injury or death.**

Be aware and understand all rules, regulations, and laws.  
Always reference and know your local laws.

<https://www.peopleforbikes.org/electric-bikes/policies-and-laws>

# 1. FIRST

**NOTE:** We strongly urge you to read this manual in its entirety before your first ride. At the very least, read and make sure that you understand each point in this section, and refer to the cited sections on any issue that you don't completely understand. Please note that not all eBikes have all the features described in this Manual. **Please contact BIKE.com at [cs@bike.com](mailto:cs@bike.com) or call at 1-(877)-755-2453(BIKE) or ask your dealer to point out the features of your eBike**

## A. eBike Fit

- 1. Is your eBike the right size?** To check, see Section 3.A. If your eBike is too large or too small for you, you may lose control and fall. If your new eBike is not the right size, please contact **BIKE.com** at [cs@bike.com](mailto:cs@bike.com) or call at **1-(877)-755-2453(BIKE)** or ask your dealer for all to exchange it before you ride it.
- 2. Is the saddle at the right height?** To check, see Section 3.B. If you adjust your saddle height, follow the Minimum Insertion instructions in Section 3.B.
- 3. Are saddle and seat post securely clamped?** A correctly tightened saddle will allow no saddle movement in any direction. See Section 3.B.
- 4. Are the stem and handlebars at the right height for you?** If not, see Section 3.C.
5. Can you comfortably operate the brakes? If not, you may be able to adjust their angle and reach. See Section 3.D and 3.E.
- 6. Do you fully understand how to operate your new eBike?** If not, before your first ride, please contact **BIKE.com** at [cs@bike.com](mailto:cs@bike.com) or call at **1-(877)-755-2453(BIKE)** or have your dealer explain any functions or features that you do not understand.

## B. Safety First

- 1. Always wear an approved helmet** when riding your eBike, and follow the helmet manufacturer's instructions for fit, use and care.
- 2. Do you have all the other required and recommended safety equipment?** See Section 2. It's your responsibility to familiarize yourself with the laws of the areas where you ride, and to comply with all applicable laws.
- 3. Do you know how to correctly secure your front and rear wheels?** Check Section 4.A.1 to make sure. Riding with an improperly secured wheel can cause the wheel to wobble or disengage from the eBike and cause serious injury or death.
- 4. If your eBike has toeclips and straps or clipless ("step-in") pedals,** make sure you know how they work (see Section 4.E). These pedals require special techniques and skills. Follow the pedal manufacturer's instructions for use, adjustment, and care.
- 5. Do you have "toe overlap"?** On smaller framed eBikes your toe or toeclip may be able to contact the front wheel when a pedal is all the way forward and the wheel is turned. Read Section 4.E. to check whether you have toeclip overlap.
- 6. Does your eBike have suspension?** If so, check Section 4.F. Suspension can change the way an eBike performs. Follow the suspension manufacturer's instructions for use, adjustment, and care.

## C. Anatomy of Your Bike

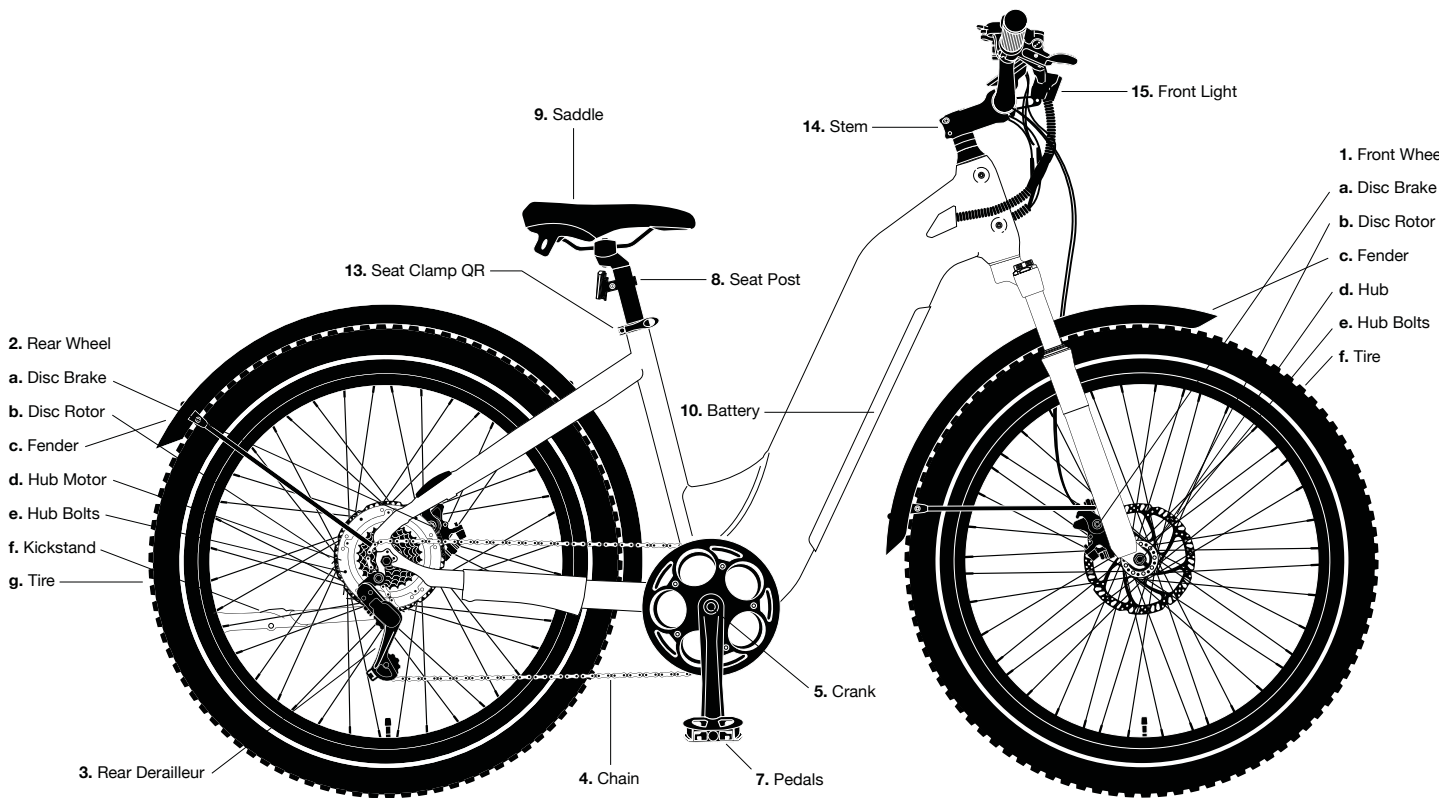

## D. Mechanical Safety Check

Routinely check the condition of your eBike before every ride.

**Nuts, bolts screws & other fasteners:** Because manufacturers use a wide variety of fastener sizes and shapes made in a variety of materials, often differing by model and component, the correct tightening force or torque cannot be generalized. To make sure that the many fasteners on your eBike are correctly tightened, refer to the Fastener Torque Specifications in Appendix E of this manual or to the torque specifications in the instructions provided by the manufacturer of the component in question. Correctly tightening a fastener requires a calibrated torque wrench. A professional eBike mechanic with a torque wrench should torque the fasteners on your eBike. If you choose to work on your own eBike, you must use a torque wrench and the correct tightening torque specifications from the eBike or component manufacturer or from your dealer. If you need to make an adjustment at home or in the field, we urge you to exercise care, and to have the fasteners you worked on checked by your dealer as soon as possible.

*Note that there are some components that require special tools and knowledge. In Sections 3 and 4 we discuss the items that you may be able to adjust yourself. All other adjustments and repairs should be done by a qualified eBike mechanic.*

**⚠️ WARNING: Correct tightening force on fasteners – nuts, bolts, screws – on your eBike is important. Too little force, and the fastener may not hold securely. Too much force, and the fastener can strip threads, stretch, deform, or break. Either way, incorrect tightening force can result in component failure, which can cause you to lose control and fall.**

☐ **Make sure nothing is loose.** Lift the front wheel off the ground by two or three inches, then let it bounce on the ground. Anything sound, feel or look loose? Do a visual and tactile inspection of the whole eBike. Any loose parts or accessories? If so, secure them. If you're not sure, ask someone with experience to check.

☐ **Tires & Wheels:** Make sure tires are correctly inflated (see Section 4.G.). Check by putting one hand on the saddle, one on the intersection of the handlebars and stem, then bouncing your weight on the eBike while looking at tire deflection. Compare what you see with how it looks when you know the tires are correctly inflated; and adjust if necessary.

☐ **Tires in good shape?** Spin each wheel slowly and look for cuts in the tread and sidewall. Replace damaged tires before riding the eBike.

☐ **Wheels true?** Spin each wheel and check for brake clearance and side-to-side wobble. If a wheel wobbles side to side even slightly, or rubs against or hits the brake pads, take the eBike to a qualified eBike shop to have the wheel trued.

**⚠️ CAUTION: Wheels must be true for rim brakes to work effectively. Wheel truing is a skill that requires special tools and experience. Do not attempt to true a wheel unless you have the knowledge, experience and tools needed to do the job correctly.**

☐ **Wheel rims clean and undamaged?** Make sure the rims are clean and undamaged at the tire bead and, if you have rim brakes, along the braking surface. Check to make sure that any rim wear indicator marking is not visible at any point on the wheel rim.

**⚠️ WARNING: eBike wheel rims are subject to wear. Please contact BIKE.com at cs@bike.com or call at 1-(877)-755-2453(BIKE) or ask your dealer for all service about wheel rim wear. Some wheel rims have a rim wear indicator that becomes visible as the rim's braking surface wears. A visible rim wear indicator on the side of the wheel rim is an indication that the wheel rim has reached its maximum usable life. Riding a wheel that is at the end of its usable life can result in wheel failure, which can cause you to lose control and fall.**

☐ **Brakes:** Check the brakes for proper operation (see Section 4.C). Squeeze the brake levers. Are the brake quick-releases closed? All control cables seated and securely engaged? If you have rim brakes, do the brake pads contact the wheel rim squarely and make full contact with the rim? Do the brakes begin to engage within an inch of brake lever movement? Can you apply full braking force at the levers without having them touch the handlebar? If not, your brakes need adjustment. Do not ride the eBike until the brakes are properly adjusted by a professional eBike mechanic.

☐ **Wheel retention system:** Make sure the front and rear wheels are correctly secured. See Section 4.A.

☐ **Seat post:** If your seat post has an over-center cam action fastener for easy height adjustment, check that it is properly adjusted and in the locked position. See Section 4.B.



□ **Handlebar and saddle alignment:** Make sure the saddle and handlebar stem are parallel to the eBikes center line and clamped tight enough so that you can't twist them out of alignment. See Sections 3.B and 3.C.

□ **Handlebar ends:** Make sure the handlebar grips are secure and in good condition, with no cuts, tears, or worn-out areas. If not, have your dealer replace them. Make sure the handlebar ends and extensions are covered or have plugs. If not, replace them before you ride. If the handlebars have bar end extensions, make sure they are clamped tight enough so you can't twist them.

**⚠ WARNING: Loose or damaged handlebar grips or extensions can cause you to lose control and fall. Unplugged handlebars or extensions can cut you and cause serious injury in an otherwise minor accident**

**VERY IMPORTANT SAFETY NOTE:**

**Please also read and become thoroughly familiar with the important information on the lifespan of your eBike and its components in Appendix C on Page 64-71**

## **E. First ride**

When you buckle on your helmet and go for your first familiarization ride on your new eBike, be sure to pick a controlled environment, away from cars, other cyclists, obstacles, or other hazards. Ride to become familiar with the controls, features, and performance of your new eBike.

Familiarize yourself with the braking action of the eBike (see Section 4.C). Test the brakes at slow speed, putting your weight toward the rear and gently applying the brakes, rear brake first. Sudden or excessive application of the front brake could pitch you over the handlebars. Applying brakes too hard can lock up a wheel, which could cause you to lose control and fall. Skidding is an example of what can happen when a wheel locks up.

If your eBike has toeclips or clipless pedals, practice getting in and out of the pedals. See Section 1.B and 4.E.

If your eBike has suspension, familiarize yourself with how the suspension responds to brake application and rider weight shifts. See paragraph B.6 above and Section 4.F.

Practice shifting the gears (see Section 4.D). Remember to never move the shifter while pedaling backward, nor pedal backwards immediately after having moved the shifter. This could jam the chain and cause serious damage to the eBike.

**Practice and use in a controlled and safe environment the E-features of the throttle & monitor to understand how to add the motorized speed and the impacts and effects it has on all aspects of the eBike features from comfort, to handling, and breaking. Be comfortable and safe, if not consult BIKE.com at [cs@bike.com](mailto:cs@bike.com) or call at 1-(877)-755-2453(BIKE) or ask your dealer**

**If you have any questions, or if you feel anything about the eBike is not as it should be, consult BIKE.com at [cs@bike.com](mailto:cs@bike.com) or call at 1-(877)-755-2453(BIKE) or ask your dealer your dealer before you ride again.**

## 2. SAFETY

### A. The Basics

**⚠️ WARNING: The area in which you ride may require specific safety devices. It is your responsibility to familiarize yourself with the laws of the area where you ride and to comply with all applicable laws, including properly equipping yourself and your eBike as the law requires.**

**Observe all local eBike laws and regulations. Observe regulations about eBike lighting, licensing of eBikes, age requirements, riding on sidewalks, laws regulating eBike path and trail use, helmet laws, child carrier laws, special eBike traffic laws. It's your responsibility to know and obey the laws.**

1. Always wear a cycling helmet that meets the latest certification standards and is appropriate for the type of riding you do. Always follow the helmet manufacturer's instructions for fit, use and care of your helmet. Most serious eBike injuries involve head injuries that might have been avoided if the rider had worn an appropriate helmet.

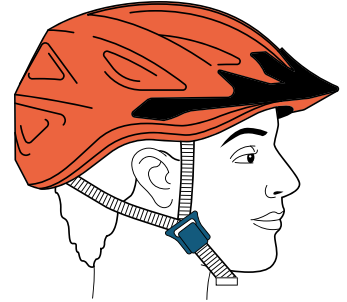

**⚠️ WARNING: Failure to wear a helmet when riding may result in serious injury or death.**

2. Always do the Mechanical Safety Check (Section 1.D.) before you get on a eBike.
3. Be thoroughly familiar with the controls of your eBike: brakes (Section 4.C.); pedals (Section 4.E.); shifting (Section 4.D.)
4. Be careful to keep body parts and other objects away from the sharp teeth of chainrings, the moving chain, the turning pedals and cranks, and the spinning wheels of your eBike.
5. Always wear:
  - Shoes that will stay on your feet and will grip the pedals. Make sure that shoelaces cannot get into moving parts, and never ride barefoot or in sandals.
  - Bright, visible clothing that is not so loose that it can be tangled in the eBike or snagged by objects at the side of the road or trail.
  - Protective eyewear, to protect against airborne dirt, dust, and bugs — tinted when the sun is bright, clear when it's not.
6. Unless your eBike was specifically designed for jumping (See Appendix B, Intended Use) don't jump with your eBike. Jumping a eBike, particularly a BMX or mountain eBike, can be fun; but it can put huge and unpredictable stress on the eBike and its components. Riders who insist on jumping their eBikes risk serious damage, to their eBikes as well as to themselves. Before you attempt to jump, do stunt riding or race with your eBike, read and understand Section 2.F.
7. Ride at a speed appropriate for conditions. Higher speed means higher risk.

## B. Riding Safety

1. Obey all Rules of the Road and all local traffic laws.
2. You are sharing the road or the path with others — motorists, pedestrians, and other cyclists. Respect their rights.
3. Ride defensively. Always assume that others do not see you.
4. Look ahead, and be ready to avoid:
  - Vehicles slowing or turning, entering the road or your lane ahead of you, or coming up behind you.
  - Parked car doors opening.
  - Pedestrians stepping out.
  - Children or pets playing near the road.
  - Potholes, sewer grating, railroad tracks, expansion joints, road or sidewalk construction, debris and other obstructions that could cause you to swerve into traffic, catch your wheel or cause you to have an accident.
  - The many other hazards and distractions which can occur on an eBike ride.
5. Ride in designated eBike lanes, on designated eBike paths or as close to the edge of the road as practicable, in the direction of traffic flow or as directed by local governing laws.
6. Stop at stop signs and traffic lights; slow down and look both ways at street intersections. Remember that an eBike always loses in a collision with a motor vehicle, so be prepared to yield even if you have the right of way.
7. Use approved hand signals for turning and stopping. (FIG 3)
8. Never ride with headphones. They mask traffic sounds and emergency vehicle sirens, distract you from concentrating on what's going on around you, and their wires can tangle in the moving parts of the eBike, causing you to lose control.
9. Never carry a passenger; and, before installing a child carrier or trailer, check with your dealer or the eBike manufacturer to make sure the eBike is designed for it. If the eBike is suitable for a child carrier or trailer, make sure that the carrier or trailer is correctly mounted, and the child is secured and wearing an approved helmet.
10. Never carry anything which obstructs your vision or your complete control of the eBike, or which could become entangled in the moving parts of the eBike.
11. Never hitch a ride by holding on to another vehicle.
12. Don't do stunts, wheelies or jumps. If you intend to do stunts, wheelies, jumps or go racing with your eBike despite our advice not to read Section 2.F, *Downhill, Stunt or Competition Biking*, **now**. Think carefully about your skills before deciding to take the large risks that go with this kind of riding.
13. Don't weave through traffic or make any moves that may surprise people with whom you are sharing the road.
14. Observe and yield the right of way.
15. Never ride your eBike while under the influence of alcohol or drugs.
16. If possible, avoid riding in bad weather, when visibility is obscured, at dawn, dusk or in the dark, or when extremely tired. Each of these conditions increases the risk of accident.

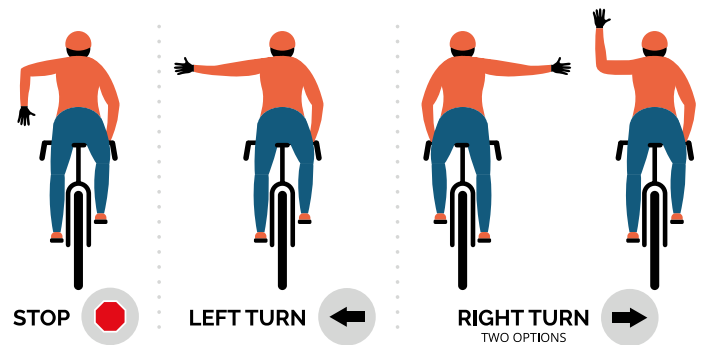

Fig. 3

## C. Off Road Safety

We recommend that children not ride on rough terrain unless they are accompanied by an adult.

**Unless your eBike was specifically designed for Off Road Riding (See Appendix B, Intended Use) don't ride this terrain with your eBike**

1. The variable conditions and hazards of off-road riding require close attention and specific skills. Start slowly on easier terrain and build up your skills. If your eBike has suspension, the increased speed you may develop also increases your risk of losing control and falling. Get to know how to handle your eBike safely before trying increased speed or more difficult terrain.
2. Wear safety gear appropriate to the kind of riding you plan to do.
3. Don't ride alone in remote areas. Even when riding with others, make sure that someone knows where you're going and when you expect to be back.
4. Always take along some kind of identification, so that people know who you are in case of an accident; and take along some cash for food, a cool drink or an emergency phone call.
5. Yield right of way to pedestrians and animals. Ride in a way that does not frighten or endanger them and give them enough room so that their unexpected moves don't endanger you.
6. Be prepared. If something goes wrong while you're riding off-road, help may not be close.
7. Before you attempt to jump, do stunt riding or race with your eBike, read and understand Section 2.F.

## Off Road respect

Obey the local laws regulating where and how you can ride off-road, and respect private property. You may be sharing the trail with others — hikers, trail runners, equestrians, and other cyclists. Respect their rights. Stay on the designated trail. Don't contribute to erosion by riding in mud or with unnecessary sliding. Don't disturb the ecosystem by cutting your own trail or shortcut through vegetation or streams. It is your responsibility to minimize your impact on the environment. Leave things as you found them; and always take out everything you brought in.

## D. Wet Weather Riding

**⚠️ WARNING: Wet weather impairs traction, braking and visibility, both for the bicyclist and for other vehicles sharing the road. The risk of an accident is dramatically increased in wet conditions.**

Under wet conditions, the stopping power of your brakes (as well as the brakes of other vehicles sharing the road) is dramatically reduced and your tires don't grip nearly as well. This makes it harder to control speed and easier to lose control. To make sure that you can slow down and stop safely in wet conditions, ride more slowly and apply your brakes earlier and more gradually than you would under normal, dry conditions. See also Section 4.C.

## E. Night Riding

Riding an eBike at night is much more dangerous than riding during the day. A bicyclist is very difficult for motorists and pedestrians to see. Therefore, children should never ride at dawn, at dusk or at night. Adults who chose to accept the greatly increased risk of riding at dawn, at dusk or at night need to take extra care both riding and choosing specialized equipment that helps reduce that risk. Consult your dealer about night riding safety equipment.

**⚠️ WARNING: Reflectors are not a substitute for required lights. Riding at dawn, at dusk, at night or at other times of poor visibility without an adequate eBike lighting system and without reflectors is dangerous and may result in serious injury or death.**

eBike reflectors are designed to pick up and reflect car lights and streetlights in a way that may help you to be seen and recognized as a moving bicyclist.

**⚠️ CAUTION: Check reflectors and their mounting brackets regularly to make sure that they are clean, straight, unbroken and securely mounted. Have your dealer replace damaged reflectors and straighten or tighten any that are bent or loose.**

The mounting brackets of front and rear reflectors are often designed as brake straddle cable safety catches which prevent the straddle cable from catching on the tire tread if the cable jumps out of its yoke or breaks.

**⚠️ WARNING: Do not remove the front or rear reflectors or reflector brackets from your eBike. They are an integral part of the eBikes safety system. Removing the reflectors reduces your visibility to others using the roadway. Being struck by other vehicles may result in serious injury or death. The reflector brackets may protect you from a brake straddle cable catching on the tire in the event of brake cable failure. If a brake straddle cable catches on the tire, it can cause the wheel to stop suddenly, causing you to lose control and fall.**

If you choose to ride under conditions of poor visibility, check and be sure you comply with all local laws about night riding, and take the following strongly recommended additional precautions:

- Purchase and install battery or generator powered head and taillights which meet all regulatory requirements for where you live and provide adequate visibility.
- Wear light colored, reflective clothing and accessories, such as a reflective vest, reflective arm and leg bands, reflective stripes on your helmet, flashing lights attached to your body and/or your eBike ... any reflective device or light source that moves will help you get the attention of approaching motorists, pedestrians, and other traffic.
- Make sure your clothing or anything you may be carrying on the eBike does not obstruct a reflector or light.
- Make sure that your eBike is equipped with correctly positioned and securely mounted reflectors.

### While riding at dawn, at dusk or at night:

- Ride slowly.
- Avoid dark areas and areas of heavy or fast-moving traffic.
- Avoid road hazards.
- If possible, ride on familiar routes.

### If riding in traffic:

- Be predictable. Ride so that drivers can see you and predict your movements.
- Be alert. Ride defensively and expect the unexpected.
- If you plan to ride in traffic often, **please contact BIKE.com at cs@bike.com or call at 1-(877)-755-2453(BIKE) or ask your dealer about traffic safety classes or a good book on eBike/bike traffic safety.**

## F. Extreme, stunt or competition riding

Whether you call it *Aggro*, *Hucking*, *Freeride*, *North Shore*, *Downhill*, *Jumping*, *Stunt Riding*, *Racing*, *Enduro* or something else: if you engage in this sort of extreme, aggressive riding, you voluntarily assume a greatly increased risk of injury or death.

Not all eBikes are designed for these types of riding, and those that are may not be suitable for all types of aggressive riding. Check with your dealer or the eBikes manufacturer about the suitability of your eBike before engaging in extreme riding.

When riding fast downhill, you can reach speeds achieved by motorcycles, and therefore face similar hazards and risks. Have your eBike and equipment carefully inspected by a qualified mechanic and be sure it is in perfect condition. Consult with expert riders, area site personnel and race officials on conditions and equipment advisable at the site where you plan to ride. Wear appropriate safety gear, including an approved full-face helmet, full finger gloves, and body armor. Ultimately, it is your responsibility to have proper equipment and to be familiar with course conditions.

**⚠ WARNING: Although many catalogs, advertisements and articles about bicycling depict riders engaged in extreme riding, this activity is extremely dangerous, increases your risk of injury or death, and increases the severity of any injury. Remember that the action depicted is being performed by professionals with many years of training and experience. Know your limits and always wear a helmet and other appropriate safety gear. Even with state-of-the-art protective safety gear, you could be seriously injured or killed when jumping, stunt riding, riding downhill at speed or in competition**

**⚠️ WARNING: eBikes and eBike parts have limitations with regard to strength and integrity, and this type of riding can exceed those limitations or dramatically reduce the length of their safe use.**

We recommend against this type of riding because of the increased risks; but if you choose to take the risk, at least:

Take lessons from a competent instructor first

- Start with easy learning exercises and slowly develop your skills before trying more difficult or dangerous riding
- Use only designated areas for stunts, jumping, racing or fast downhill riding
- Wear a full-face helmet, safety pads and other safety gear
- Understand and recognize that the stresses imposed on your eBike by this kind of activity may break or damage parts of the eBike and void the warranty
- Take your eBike to your dealer if anything breaks or bends. Do not ride your eBike when any part is damaged.

If you ride downhill at speed, do stunt riding or ride in competition, know the limits of your skill and experience. Ultimately, avoiding injury is your responsibility.

## **G. Changing Components or Adding Accessories**

There are many components and accessories available to enhance the comfort, performance, and appearance of your eBike. However, if you change components or add accessories, you do so at your own risk. The eBikes manufacturer may not have tested that component or accessory for compatibility, reliability, or safety on your eBike. Before installing any component or accessory, including but not limited to a different size tire, a lighting system, a luggage rack, a child seat, a trailer, etc., make sure that it is compatible with your eBike by checking with your dealer. Be sure to read, understand and follow the instructions that accompany the products you purchase for your eBike. See also Appendix B, p. 38 and C, p. 44.

**⚠️ WARNING: Failure to confirm compatibility, properly install, operate and maintain any component or accessory can result in serious injury or death.**

**⚠️ WARNING: Exposed springs on the saddle of any eBike fitted with a child seat can cause serious injury to the child.**

**⚠️ WARNING: Changing the components on your eBike with other than genuine replacement parts may compromise the safety of your eBike and may void the warranty. Check with your dealer before changing the components on your eBike.**

## H. E-Component

**⚠️ WARNING:**The battery pack voltage must match the battery pack charging voltage of the charger. Otherwise, there is a risk of fire and or explosion. **ONLY** use the factory provided system of battery and charger.

**DO NOT** modify alter or make any changes to your E-Components- Battery, Motor, Monitor, and or Throttle. Any changes, modifications and/or altering will void warranty and could cause injury, serious injury or even death.

Changing the Assistance Level- Changing the E-Assist level while riding will increase or decrease the acceleration of your eBike. You should show extreme caution and be very familiar with this system and the changes. Be aware of your surroundings, traffic, weather, etc., not traction, awareness, and overall handling can be influenced with these changes.

eBikes are heavier than traditional bikes. Be aware. Park to be safe and insure they cannot fall over or cause damage to you or anyone or your bike.

**DO NOT** ride of submerge your eBike in water. You could lose control but also could cause erious damage to your eBike components.

**Child Safety** - if wishing to use a bike trailer please contact and consult with the trailer manufacturer to ensure compatibility.

**Bicycle Rack for Car** - if wishing to use a car rack, trailer hitch rack or any type of device to transport your eBike please contact and consult the rack manufacturer.  
Your eBike is heavy, and you may need a specific and or unique rack.

Be aware and understand all rules, regulations, and laws.  
Always reference and know your local laws.

<https://www.peopleforbikes.org/electric-bikes/policies-and-laws>

If you have any questions, or if you feel anything about the eBike is not as it should be, consult BIKE.com at [cs@bike.com](mailto:cs@bike.com) or call at 1-(877)-755-2453(BIKE) or ask your dealer your dealer before you ride



## 3. Fit

**NOTE: Correct fit is an essential element of bicycling safety, performance and comfort. Making the adjustments to your eBike that result in correct fit for your body and riding conditions requires experience, skill, and special tools. Always have your dealer make the adjustments on your eBike; or, if you have the experience, skill, and tools, have your dealer check your work before riding.**

**⚠ WARNING: If your eBike does not fit properly, you may lose control and fall. If your new eBike doesn't fit, please contact BIKE.com at [cs@bike.com](mailto:cs@bike.com) or call at 1-(877)-755-2453(BIKE) or ask your dealer for all service to exchange it before you ride it.**

### A. Stand over height

#### 1. Top Tube frame eBikes



Stand over height is the basic element of eBike fit (fig. 4). It is the distance from the ground to the top of the eBikes frame at that point where your crotch is when straddling the eBike. To check for correct stand over height, straddle the eBike while wearing the kind of shoes in which you'll be riding, and bounce vigorously on your heels. If your crotch touches the frame, the eBike is too big for you. Don't even ride the eBike around the block. An eBike which you ride only on paved surfaces and never take off-road should give you a minimum stand over height clearance of two inches (5 cm). An eBike that you'll ride on unpaved surfaces should give you a minimum of three inches (7.5 cm) of stand over height clearance. And an eBike that you'll use off road should give you four inches (10 cm) or more of clearance.

#### 2. Step-through frame eBikes

Stand over height does not apply to eBikes with step-through frames. Instead, the limiting dimension is determined by saddle height range. You must be able to adjust your saddle position as described in 3.B without exceeding the limits set by the height of the top of the seat tube and the "Minimum Insertion" or "Maximum Extension" mark on the seat post.

## B. Saddle position

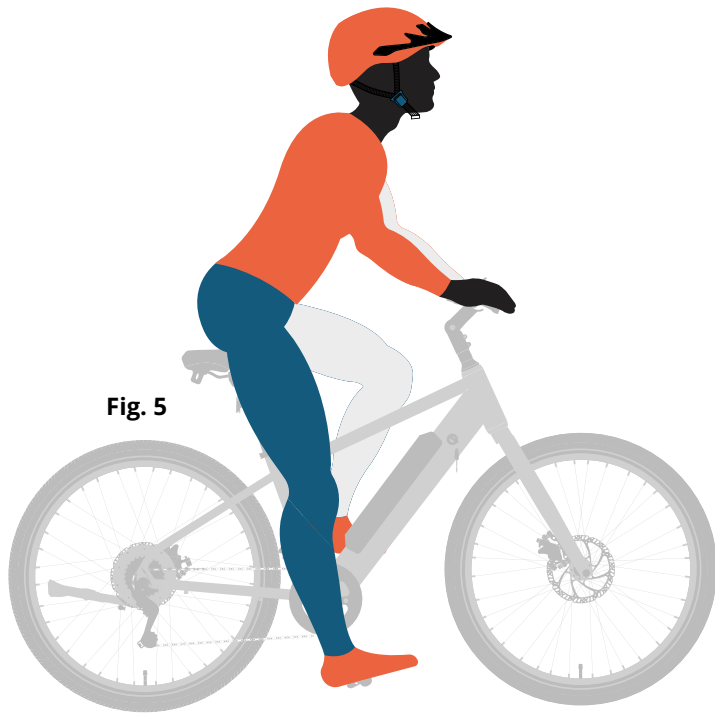

Correct saddle adjustment is an important factor in getting the most performance and comfort from your eBike. If the saddle position is not comfortable for you, see your dealer.

The saddle can be adjusted in three directions:

1. Up and down adjustment.

To check for correct saddle height (fig. 5):

- sit on the saddle.
- place one heel on a pedal.
- rotate the crank until the pedal with your heel on it is in the down position and the crank arm is parallel to the seat tube.

If your leg is not completely straight, your saddle height needs to be adjusted. If your hips must rock for the heel to reach the pedal, the saddle is too high. If your leg is bent at the knee with your heel on the pedal, the saddle is too low. Please go step by step to adjust

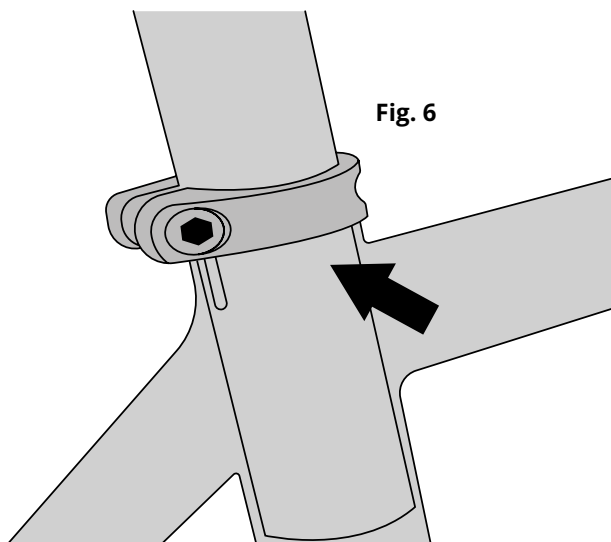

- Loosen the seat post clamp**
- Raise or lower the seat post in the seat tube**
- Make sure the saddle is straight fore and aft**
- Re-tighten the seat post clamp to the recommended torque (Appendix D or the manufacturer's instructions).**

Once the saddle is at the correct height, make sure that the seat post does not project from the frame beyond its "Minimum Insertion" or "Maximum Extension" mark (FIG. 6).

**NOTE:** Some eBikes have a sight hole in the seat tube, the purpose of which is to make it easy to see whether the seat post is inserted in the seat tube far enough to be safe.

If your eBike has such a sight hole, use it instead of the “Minimum Insertion” or “Maximum Extension” mark to make sure the seat post is inserted in the seat tube far enough to be visible through the sight hole.

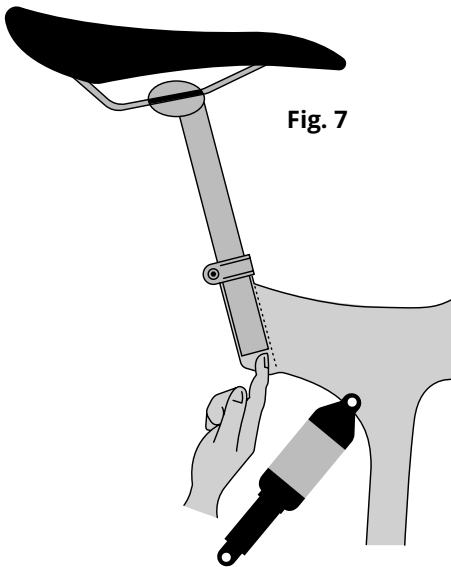

If your eBike has an interrupted seat tube, as is the case on some suspension eBikes, you must also make sure that the seat post is far enough into the frame so that you can touch it through the bottom of the interrupted seat tube with the tip of your finger without inserting your finger beyond its first knuckle. *Also see NOTE above and FIG 7).*

**⚠ WARNING: If your seat post is not inserted in the seat tube as described in B.1 above, the seat post, binder or even frame may break, which could cause you to lose control and fall.**

**2. Front and back adjustment.** The saddle can be adjusted forward or back to help you get the optimal position on the eBike. Please contact **BIKE.com** at [cs@bike.com](mailto:cs@bike.com) or call at **1-(877)-755-2453(BIKE)** or ask your dealer for all service to set the saddle for your optimal riding position and to show you how to make this adjustment. If you choose to make your own front and back adjustment, make sure that the clamp mechanism is clamping on the straight part of the saddle rails and is not touching the curved part of the rails, and that you are using the recommended torque on the clamping fastener(s) (Appendix E or the manufacturer’s instructions) through the sight hole.

**3. Saddle angle adjustment.** Most people prefer a horizontal saddle; but some riders like the saddle nose angled up or down just a little. Your dealer can adjust saddle angle or teach you how to do it. If you choose to make your own saddle angle adjustment and you have a single bolt saddle clamp on your seat post, it is critical that you loosen the clamp bolt sufficiently to allow any serrations on the mechanism to disengage before changing the saddle’s angle, and then that the serrations fully re-engage before you tighten the clamp bolt to the recommended torque (Appendix E or the manufacturer’s instructions).

**⚠ WARNING: When making saddle angle adjustments with a single bolt saddle clamp, always check to make sure that the serrations on the mating surfaces of the clamp are not worn. Worn serrations on the clamp can allow the saddle to move, causing you to lose control and fall.**

**Always tighten fasteners to the correct torque. Bolts that are too tight can stretch and deform. Bolts that are too loose can move and fatigue. Either mistake can lead to a sudden failure of the bolt, causing you to lose control and fall.**

**Note: If your eBike is equipped with a suspension seat post, the suspension mechanism may require periodic service or maintenance. Please contact BIKE.com at [cs@bike.com](mailto:cs@bike.com) or call at 1-(877)-755-2453(BIKE) or ask your dealer for all service for recommended service intervals for your suspension seat post.**

Small changes in saddle position can have a substantial effect on performance and comfort. To find your best saddle position, make only one adjustment at a time.

**⚠ WARNING: After any saddle adjustment, be sure that the saddle adjusting mechanism is properly seated and tightened before riding. A loose saddle clamp or seat post clamp can cause damage to the seat post or can cause you to lose control and fall. A correctly tightened saddle adjusting mechanism will allow no saddle movement in any direction. Periodically check to make sure that the saddle adjusting mechanism is properly tightened.**

If, in spite of carefully adjusting the saddle height, tilt and fore-and-aft position, your saddle is still uncomfortable, you may need a different saddle design. Saddles, like people, come in many different shapes, sizes and resilience. Your dealer can help you select a saddle which, when correctly adjusted for your body and riding style, will be comfortable.

**⚠ WARNING: Some people have claimed that extended riding with a saddle which is incorrectly adjusted, or which does not support your pelvic area correctly can cause short-term or long-term injury to nerves and blood vessels, or even impotence. If your saddle causes you pain, numbness, or other discomfort, listen to your body and stop riding until you see your dealer about saddle adjustment or a different saddle.**

Please contact BIKE.com at [cs@bike.com](mailto:cs@bike.com) or call at 1-(877)-755-2453(BIKE) or ask your dealer for all service to set the saddle for your optimal riding position and to show you how to make this adjustment.

If you choose to make your own saddle height adjustment:

## C. Handlebar height and angle

Your eBike is equipped either with a “threadless” stem, which clamps on to the outside of the steerer tube, or with a “quill” stem, which clamps inside the steerer tube by way of an expanding binder bolt. If you aren’t absolutely sure which type of stem your eBike has, please contact **BIKE.com** at [cs@bike.com](mailto:cs@bike.com) or call at 1-(877)-755-2453(BIKE) or ask your dealer.

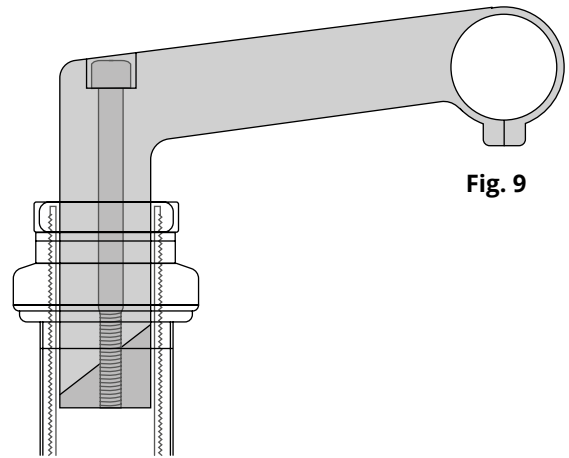
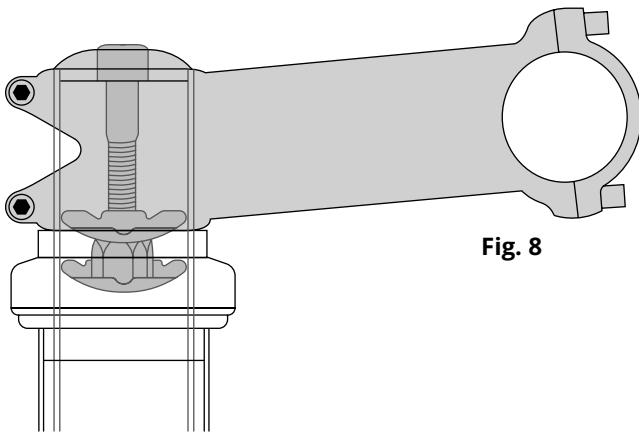

If your Ebike has a “threadless” stem (FIG 8) your dealer may be able to change handlebar height by moving height adjustment spacers from below the stem to above the stem, or vice versa. Otherwise, you’ll have to get a stem of different length or rise. Consult your dealer. Do not attempt to do this yourself, as it requires special knowledge.

If your Ebike has a “quill” stem (FIG 9) Please contact **BIKE.com** at [cs@bike.com](mailto:cs@bike.com) or call at 1-(877)-755-2453(BIKE) or ask your dealer for support to adjust the handlebar height a bit by adjusting stem height. A quill stem has an etched or stamped mark on its shaft that designates the stem’s “Minimum Insertion” or “Maximum Extension”. This mark must not be visible above the headset.

**⚠ WARNING: A quill stem’s Minimum Insertion Mark must not be visible above the top of the headset. If the stem is extended beyond the Minimum Insertion Mark the stem may break or damage the fork’s steerer tube, which could cause you to lose control and fall.**

**⚠ WARNING: On some Ebikes, changing the stem or stem height can affect the tension of the front brake cable, locking the front brake or creating excess cable slack which can make the front brake inoperable. If the front brake pads move in towards the wheel rim or out away from the wheel rim when the stem or stem height is changed, the brakes must be correctly adjusted before you ride the Ebike.**

Some Ebikes are equipped with an adjustable angle stem. If your Ebike has an adjustable angle stem, please, contact **BIKE.com** at [cs@bike.com](mailto:cs@bike.com) or call at 1-(877)-755-2453(BIKE) or ask your dealer for all service to show you how to adjust. Do not attempt to make the adjustment yourself, as changing stem angle may also require adjustments to the Ebikes controls.

**⚠️ WARNING: Always tighten fasteners to the correct torque. Bolts that are too tight can stretch and deform. Bolts that are too loose can move and fatigue. Either mistake can lead to a sudden failure of the bolt, causing you to lose control and fall.**

It is also possible to adjust the angle of the handlebar or bar end extensions and control items, please contact BIKE.com at [cs@bike.com](mailto:cs@bike.com) or call at 1-(877)-755-2453(BIKE) or ask your dealer for all service to show you how to adjust.

**⚠️ WARNING: An insufficiently tightened stem clamp bolt, handlebar clamp bolt or bar end extension clamping bolt may compromise steering action, which could cause you to lose control and fall. Place the front wheel of the Ebike between your legs and attempt to twist the handlebar/stem assembly. If you can twist the stem in relation to the front wheel, turn the handlebars in relation to the stem, or turn the bar end extensions in relation to the handlebar, the bolts are insufficiently tightened.**

**⚠️ WARNING: Be aware that adding aerodynamic extensions to handlebars will change the steering and braking response of the Ebike.**

## **D. Control position adjustments**

The angle of the brake and shift control levers and their position on the handlebars can be changed. Please contact BIKE.com at [cs@bike.com](mailto:cs@bike.com) or call at 1-(877)-755-2453(BIKE) or ask your dealer for all service to make the adjustments for you. If you choose to make your own control lever angle adjustment, be sure to re-tighten the clamp fasteners to the recommended torque (Appendix E or the manufacturer's instructions).

## **E. Brake reach**

Many Ebikes have brake levers that can be adjusted for reach. If you have small hands or find it difficult to squeeze the brake levers, your dealer can either adjust the reach or fit shorter reach brake levers. Please contact BIKE.com at [cs@bike.com](mailto:cs@bike.com) or call at 1-(877)-755-2453(BIKE) or ask your dealer for all service to make the adjustments for you.

**⚠️ WARNING: The shorter the brake lever reach, the more critical it is to have correctly adjusted brakes, so that full braking power can be applied within available brake lever travel. Brake lever travel insufficient to apply full braking power can result in loss of control, which may result in serious injury or death.**

## 4. TECH

It's important to your safety, performance, and enjoyment to understand how things work on your Ebike. We urge you to please contact **BIKE.com** at [cs@bike.com](mailto:cs@bike.com) or call at **1-(877)-755-2453(BIKE)** or ask your dealer for support and how to do the things described in this section before you attempt them yourself, and that you have your dealer check your work before you ride the Ebike. If you have even the slightest doubt as to whether you understand something in this section of the Manual, talk to your dealer. *See also Appendix A, B, C and D.*

### A. Wheels

Ebike wheels are designed to be removable for easier transportation and for repair of a tire puncture. In most cases, the wheel axles are inserted into slots, called "dropouts" in the fork and frame, but some mountain and road Ebikes use what is called a "through axle" wheel mounting system.

**If you have a mountain or road Ebike equipped with through axle front or rear wheels, make sure that your dealer has given you the manufacturer's instructions, and follow those when installing or removing a through axle wheel. If you don't know what a through axle is, ask your dealer.**

If you do not have an Ebike with a through-axle wheel mounting system, it will have wheels secured in one of three ways:

1. A hollow axle with a shaft ("skewer") running through it which has an adjustable tension nut on one end and an over-center cam on the other (cam action system, fig.8 a & b)
2. A hollow axle with a shaft ("skewer") running through it which has a nut on one end and a fitting for a hex key, lock lever or other tightening device on the other (through bolt, fig. 9)
3. Hex nuts or hex key bolts which are threaded on to or into the hub axle (bolt-on wheel, fig. 10) Your Ebike may be equipped with a different securing method for the front wheel than for the rear wheel. Discuss the wheel securing method for your Ebike with your dealer.

**⚠ CAUTION: In some cases- an Ebike motor could be incorporated with-in the rear hub. If this is the case, please show extreme caution and care with removing the rear wheel. If you are unsure or have doubt, please seek help by contacting us at [BIKE.com](mailto:BIKE.com) at [cs@bike.com](mailto:cs@bike.com) or call at 1-(877)-755-2453(BIKE) or ask your dealer for support.**

**It is very important that you understand the type of wheel securing method on your Ebike, that you know how to secure the wheels correctly, and that you know how to apply the correct clamping force that safely secures the wheel.**

**Please contact [BIKE.com](mailto:BIKE.com) at [cs@bike.com](mailto:cs@bike.com) or call at 1-(877)-755-2453(BIKE) or ask your dealer for all service to instruct you in correct wheel removal and installation and ask for any available manufacturer's instructions.**

**⚠ WARNING: Riding with an improperly secured wheel can allow the wheel to wobble or fall off the Ebike, which can cause serious injury or death.**

Therefore, it is essential that you:

1. Please contact BIKE.com at [cs@bike.com](mailto:cs@bike.com) or call at 1-(877)-755-2453(BIKE) or ask your dealer for all service to help you make sure you know how to install and remove your wheels safely.
2. Understand and apply the correct technique for clamping your wheel in place.
3. Each time, before you ride the Ebike, check that the wheel is securely clamped. The clamping action of a correctly secured wheel must emboss the surfaces of the dropouts.

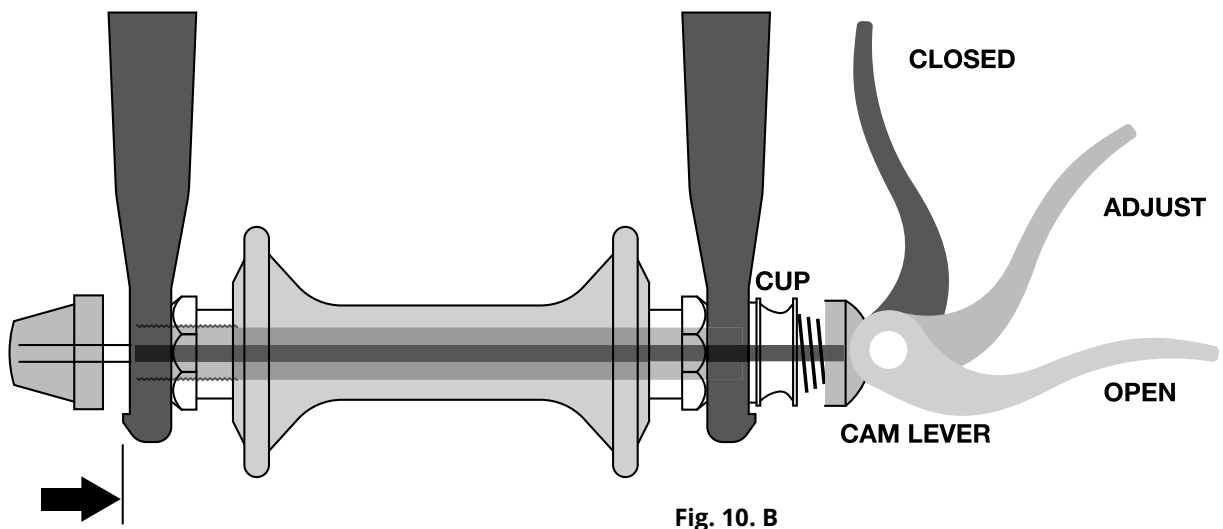
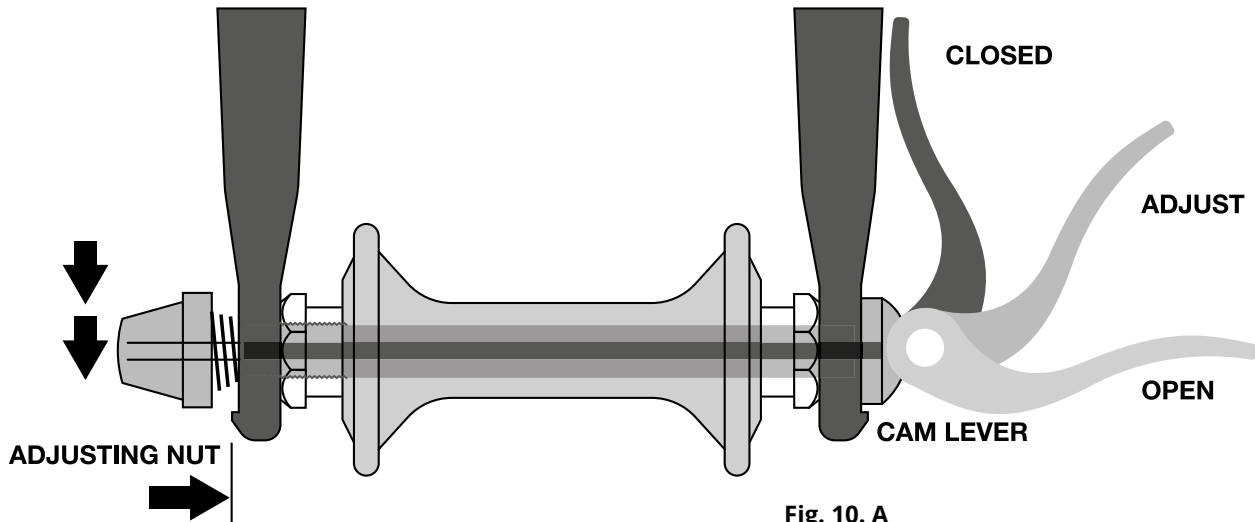



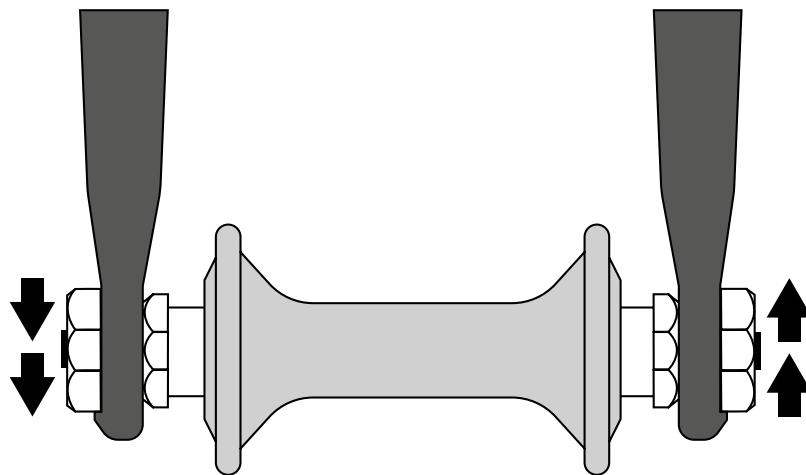
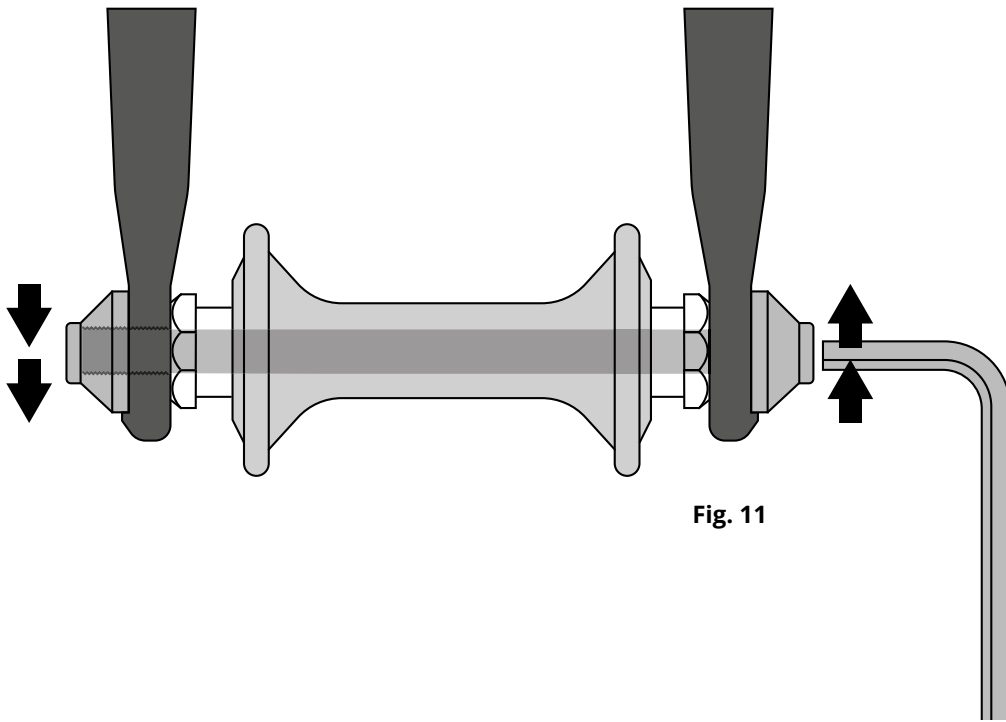

Most Ebikes have front forks that utilize a secondary wheel retention device to reduce the risk of the wheel disengaging from the fork if the wheel is incorrectly secured. Secondary retention devices are not a substitute for correctly securing your front wheel.

Secondary retention devices fall into two basic categories:

- a. The clip-on type is a part that the manufacturer adds to the front wheel hub or front fork.
- b. The integral type is molded, cast or machined into the outer faces of the front fork dropouts.

**Please contact BIKE.com at [cs@bike.com](mailto:cs@bike.com) or call at 1-(877)-755-2453(BIKE) or ask your dealer for all service to explain the particular secondary retention device on your Ebike.**

**⚠ WARNING: Do not remove or disable the secondary retention device.**

**As its name implies, it serves as a back-up for a critical adjustment. If the wheel is not secured correctly, the secondary retention device can reduce the risk of the wheel disengaging from the fork. Removing or disabling the secondary retention device may also void the warranty.**

**Secondary retention devices are not a substitute for correctly securing your wheel. Failure to properly secure the wheel can cause the wheel to wobble or disengage, which could cause you to lose control and fall, resulting in serious injury or death.**

## **2. Wheels with cam action systems**

There are currently two types of over-center cam wheel retention mechanisms:

the traditional over-center cam (FIG 10.A) and the cam-and-cup system (FIG 10.B).

Both use an over-center cam action to clamp the Ebikes wheel in place. Your Ebike may have a cam-and-cup front wheel retention system and a traditional rear wheel cam action system.

### **a. Adjusting the traditional cam action mechanism (FIG 10.A)**

The wheel hub is clamped in place by the force of the over-center cam pushing against one dropout and pulling the tension adjusting nut, by way of the skewer, against the other dropout. The amount of clamping force is controlled by the tension adjusting nut. Turning the tension adjusting nut clockwise while keeping the cam lever from rotating increases clamping force; turning it counterclockwise while keeping the cam lever from rotating reduces clamping force. Less than half a turn of the tension adjusting nut can make the difference between safe clamping force and unsafe clamping force.

**⚠ WARNING: The full force of the cam action is needed to clamp the wheel securely. Holding the nut with one hand and turning the lever like a wing nut with the other hand until everything is as tight as you can get it will not clamp a cam action wheel safely in the dropouts. See also the first WARNING in this Section 4.A.**

### **b. Adjusting the cam-and-cup mechanism (FIG 10.B)**

The cam-and-cup system on your front wheel will have been correctly adjusted for your Ebike by your dealer. Please contact **BIKE.com** at [cs@bike.com](mailto:cs@bike.com) or call at 1-(877)-755-2453(BIKE) or ask your dealer for all service to check the adjustment every six months.

**Do not use a cam-and-cup front wheel on any Ebike other than the one for which your dealer adjusted it.**

### 3. Removing and Installing wheels

**⚠ WARNING: If your Ebike is equipped with a hub brake such as a rear coaster brake, front or rear drum, band, or roller brake; or if it has an internal gear rear hub, do not attempt to remove the wheel. The removal and re-installation of most hub brakes and internal gear hubs requires special knowledge. Incorrect removal or assembly can result in brake or gear failure, which can cause you to lose control and fall.**

**CAUTION: If your Ebike has a disc brake, exercise care in touching the rotor or caliper. Disc rotors have sharp edges, and both rotor and caliper can get very hot during use.**

#### a. Removing a disk brake or rim brake Front Wheel

1. If your Ebike has rim brakes, disengage the brake's quick-release mechanism to increase the clearance between the tire and the brake pads (See Section 4.C FIG 13-17).
2. If your Ebike has cam action front wheel retention, move the cam lever from the locked or CLOSED position to the OPEN position (figs. 8a & b). If your Ebike has through bolt or bolt-on front wheel retention, loosen the fastener(s) a few turns counter-clockwise using an appropriate wrench, lock key or the integral lever.
3. If your front fork has a clip-on type of secondary retention device, disengage it. If your front fork has an integral secondary retention device, and a traditional cam action system (fig. 8a) loosen the tension adjusting nut enough to allow removing the wheel from the dropouts. If your front wheel uses a cam-and-cup system, (fig. 8b) squeeze the cup and cam lever together while removing the wheel. No rotation of any part is necessary with the cam-and-cup system. You may need to tap the top of the wheel with the palm of your hand to release the wheel from the front fork.

#### b. Installing a disk brake or rim brake Front Wheel

**⚠ CAUTION: If your Ebike is equipped with a front disk brake, be careful not to damage the disk, caliper or brake pads when re-inserting the disk into the caliper. Never activate a disk brake's control lever unless the disk is correctly inserted in the caliper. See also Section 4.C.**

1. If your Ebike has cam action front wheel retention, move the cam lever so that it curves away from the wheel (FIG 10.B). This is the OPEN position. If your Ebike has through bolt or bolt-on front wheel retention, go to the next step.
2. With the steering fork facing forward, insert the wheel between the fork blades so that the axle seats firmly at the top of the fork dropouts. The cam lever, if there is one, should be on rider's left side of the Ebike (FIG 10.A & 10.B). If your Ebike has a clip-on type of secondary retention device, engage it.
3. If you have a traditional cam action mechanism: holding the cam lever in the ADJUST position with your right hand, tighten the tension adjusting nut with your left hand until it is finger tight against the fork dropout (FIG 10.A). If you have a cam-and-cup system: the nut and cup (FIG 10.B) will have snapped into the recessed area of the fork dropouts and no adjustment should be required.

4. While pushing the wheel firmly to the top of the slots in the fork dropouts, and at the same time centering the wheel rim in the fork
  - (a) With a cam action system, move the cam lever upwards and swing it into the CLOSED position (FIG 10.A & 10.B). The lever should now be parallel to the fork blade and curved toward the wheel. To apply enough clamping force, you should have to wrap your fingers around the fork blade for leverage, and the lever should leave a clear imprint in the palm of your hand.
  - (b) With a through-bolt or bolt-on system, tighten the fasteners to the torque specifications in Appendix D or the hub manufacturer's instructions.

**NOTE:** If, on a traditional cam action system, the lever cannot be pushed all the way to a position parallel to the fork blade, return the lever to the OPEN position. Then turn the tension adjusting nut counterclockwise one-quarter turn and try tightening the lever again.

- (5) With a through-bolt or bolt-on system, tighten the fasteners to the torque specifications in Appendix D or the hub manufacturer's instructions.

**⚠ WARNING: Securely clamping the wheel with a cam action retention device takes considerable force. If you can fully close the cam lever without wrapping your fingers around the fork blade for leverage, the lever does not leave a clear imprint in the palm of your hand, and the serrations on the wheel fastener do not emboss the surfaces of the dropouts, the tension is insufficient. Open the lever; turn the tension adjusting nut clockwise a quarter turn; then try again. See also the first WARNING in this Section 4.C.**

(6) If you disengaged the brake quick-release mechanism in 4.A above, re-engage it to restore correct brake pad-to-rim clearance.

(7) Spin the wheel to make sure that it is centered in the frame and clears the brake pads; then squeeze the brake lever and make sure that the brakes are operating correctly.

### c. Removing a disk brake or rim brake Rear Wheel

**⚠ CAUTION: In some cases- an Ebike motor could be incorporated with-in the rear hub. If this is the case, please show extreme caution and care with removing the rear wheel. If you are unsure or have doubt, please seek help by contacting us at BIKE.com at cs@bike.com or call at 1-(877)-755-2453(BIKE) or ask your dealer for support.**

1. If you have a multi-speed Ebike with a derailleur gear system: shift the rear derailleur to high gear (the smallest, outermost rear sprocket).  
If you have an internal gear rear hub, consult your dealer or the hub manufacturer's instructions before attempting to remove the rear wheel.
2. If you have a single-speed Ebike with rim or disk brake, go to step (4) below.  
If your Ebike has rim brakes, disengage the brake's quick-release mechanism to increase the clearance between the wheel rim and the brake pads (see Section 4.C, FIG 13-17).
3. On a derailleur gear system, pull the derailleur body back with your right hand.

4. With a cam action mechanism, move the quick-release lever to the OPEN position (FIG 10.B). With a through bolt or bolt on mechanism, loosen the fastener(s) with an appropriate wrench, lock lever or integral lever; then push the wheel forward far enough to be able to remove the chain from the rear sprocket.
5. (5) Lift the rear wheel off the ground a few inches and remove it from the rear dropouts.

#### **d. Installing a disk brake or rim brake Rear Wheel**

**⚠ CAUTION: If your Ebike is equipped with a rear disk brake, be careful not to damage the disk, caliper or brake pads when re-inserting the disk into the caliper. Never activate a disk brake's control lever unless the disk is correctly inserted in the caliper.**

**⚠ CAUTION: In some cases- an Ebike motor could be incorporated with-in the rear hub. If this is the case, please show extreme caution and care with removing the rear wheel. If you are unsure or have doubt, please seek help by contacting us at BIKE.com at cs@bike.com or call at 1-(877)-755-2453(BIKE) or ask your dealer for support.**

1. With a cam action system, move the cam lever to the OPEN position (see FIG 10.A & 10.B). The lever should be on the side of the wheel opposite the derailleur and freewheel sprockets.
2. On a derailleur Ebike, make sure that the rear derailleur is still in its outermost, high gear, position; then pull the derailleur body back with your right hand. Put the chain on top of the smallest freewheel sprocket.
3. On a single speed, remove the chain from the front sprocket, so that you have plenty of slack in the chain. Put the chain on the rear wheel sprocket.
4. Then, insert the wheel into the frame dropouts and pull it all the way in to the dropouts.
5. On a single speed or an internal gear hub, replace the chain on the chainring; pull the wheel back in the dropouts so that it is straight in the frame and the chain has about 1/4 inches of up-and-down play.
6. With a cam action system, move the cam lever upwards and swing it into the CLOSED position (FIG 10.A & 10.B). The lever should now be parallel to the seat stay or chain stay and curved toward the wheel. To apply enough clamping force, you should have to wrap your fingers around the fork blade for leverage, and the lever should leave a clear imprint in the palm of your hand.
7. With a through-bolt or bolt-on system, tighten the fasteners to the torque specifications in Appendix D or the hub manufacturer's instructions.

**NOTE:** If, on a traditional cam action system, the lever cannot be pushed all the way to a position parallel to the seat stay or chain stay, return the lever to the OPEN position. Then turn the tension adjusting nut counterclockwise one-quarter turn and try tightening the lever again.

**⚠ WARNING: Securely clamping the wheel with a cam action retention device takes considerable force. If you can fully close the cam lever without wrapping your fingers around the seat stay or chain stay for leverage, the lever does not leave a clear imprint in the palm of your hand, and the serrations on the wheel fastener do not emboss the surfaces of the dropouts, the tension is insufficient. Open the lever; turn the tension adjusting nut clockwise a quarter turn; then try again. See also the first WARNING in this Section 4.A.**

8. If you disengaged the brake quick-release mechanism in 4.A. above, re-engage it to restore correct brake pad-to-rim clearance.
9. Spin the wheel to make sure that it is centered in the frame and clears the brake pads; then squeeze the brake lever and make sure that the brakes are operating correctly.

**⚠ CAUTION: In some cases- an Ebike motor could be incorporated with-in the rear hub. If this is the case, please show extreme caution and care with removing the rear wheel. If you are unsure or have doubt, please seek help by contacting us at BIKE.com at [cs@bike.com](mailto:cs@bike.com) or call at 1-(877)-755-2453(BIKE) or ask your dealer for support.**

It is very important that you understand the type of wheel securing method on your Ebike, that you know how to secure the wheels correctly, and that you know how to apply the correct clamping force that safely secures the wheel.

Please contact BIKE.com at [cs@bike.com](mailto:cs@bike.com) or call at 1-(877)-755-2453(BIKE) or ask your dealer for all service to instruct you in correct wheel removal and installation and ask for any available manufacturer's instructions.

## **B. Seat post cam action clamp**

Some Ebikes are equipped with a cam action seat post binder. The seat post cam action binder works exactly like the traditional wheel cam action fastener (Section 4.A.2). While a cam action binder looks like a long bolt with a lever on one end and a nut on the other, the binder uses an over-center cam action to firmly clamp the seat post (see FIG 10.A & 10.B).

**⚠ WARNING: Riding with an improperly tightened seat post can allow the saddle to turn or move and cause you to lose control and fall. Therefore:**

1. Please contact BIKE.com at [cs@bike.com](mailto:cs@bike.com) or call at 1-(877)-755-2453(BIKE) or ask your dealer for all service to help you make sure you know how to correctly clamp your seat post.
2. Understand and apply the correct technique for clamping your seat post.
3. Before you ride the Ebike, first check that the seat post is securely clamped.

## Adjusting the seat post cam action mechanism

The action of the cam squeezes the seat collar around the seat post to hold the seat post securely in place. The amount of clamping force is controlled by the tension adjusting nut. Turning the tension adjusting nut clockwise while keeping the cam lever from rotating increases clamping force; turning it counterclockwise while keeping the cam lever from rotating reduces clamping force. Less than half a turn of the tension adjusting nut can make the difference between safe and unsafe clamping force.

**⚠️ WARNING: The full force of the cam action is needed to clamp the seat post securely. Holding the nut with one hand and turning the lever like a wing nut with the other hand until everything is as tight as you can get it will not clamp the seat post safely.**

**⚠️ WARNING: If you can fully close the cam lever without wrapping your fingers around the seat post or a frame tube for leverage, and the lever does not leave a clear imprint in the palm of your hand, the tension is insufficient. Open the lever; turn the tension adjusting nut clockwise a quarter turn; then try again.**

Please contact BIKE.com at [cs@bike.com](mailto:cs@bike.com) or call at 1-(877)-755-2453(BIKE) or ask your dealer for service instructions if you are uncertain or have the slightest doubt.

## C. Brakes

There are three general types of Ebike brakes: rim brakes, which operate by squeezing the wheel rim between two brake pads; disc brakes, which operate by squeezing a hub-mounted disc between two brake pads; and internal hub brakes. All three can be operated by way of a handlebar mounted lever. On some models of Ebike, the internal hub brake is operated by pedaling backwards. This is called a Coaster Brake.

**⚠️ WARNING:**

- 1. Riding with improperly adjusted brakes, worn brake pads, or wheels on which the rim wear mark is visible is dangerous and can result in serious injury or death.**
  - 2. Applying brakes too hard or too suddenly can lock up a wheel, which could cause you to lose control and fall. Sudden or excessive application of the front brake may pitch the rider over the handlebars, which may result in serious injury or death.**
  - 3. Some Ebike brakes, such as disc brakes (fig. 11) and linear-pull brakes (fig. 12), are extremely powerful. Take extra care in becoming familiar with these brakes and exercise particular care when using them.**
  - 4. Some Ebike brakes are equipped with a brake force modulator, a small, cylindrical device through which the brake control cable runs, and which is designed to provide a more progressive application of braking force. A modulator makes the initial brake lever force more gentle, progressively increasing force until full force is achieved. If your Ebike is equipped with a brake force modulator, take extra care in becoming familiar with its performance characteristics. Some brake force modulators are adjustable.**
- If you don't like the feel of your brakes, please contact BIKE.com at [cs@bike.com](mailto:cs@bike.com) or call at 1-(877)-755-2453(BIKE) or ask your dealer for all service about adjusting the brake force modulation.**

5. Disc brakes can get extremely hot with extended use. Be careful not to touch a disc brake until it has had plenty of time to cool.

6. See the brake manufacturer's instructions for operation and care of your brakes, and for when brake pads must be replaced. If you do not have the manufacturer's instructions, see your dealer, or contact the brake manufacturer.

7. If replacing worn or damaged parts, use only manufacturer-approved genuine replacement parts.

### 1. Brake controls and features

It's very important to your safety that you learn and remember which brake lever controls which brake on your Ebike. Traditionally, in the U.S. the right brake lever controls the rear brake, and the left brake lever controls the front brake; but, to check how your Ebikes brakes are set up, squeeze one brake lever, and look to see which brake, front or rear, engages.

Now do the same with the other brake lever.

Make sure that your hands can reach and squeeze the brake levers comfortably. If your hands are too small to operate the levers comfortably, consult your dealer before riding the Ebike. The lever reach may be adjustable; or you may need a different brake lever design.

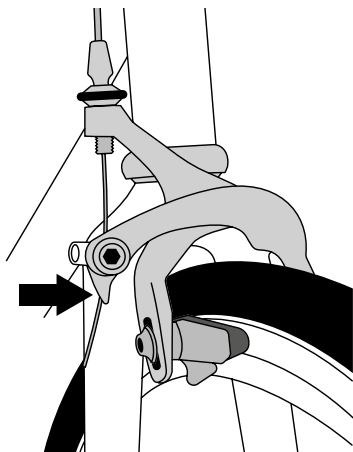

Fig. 16

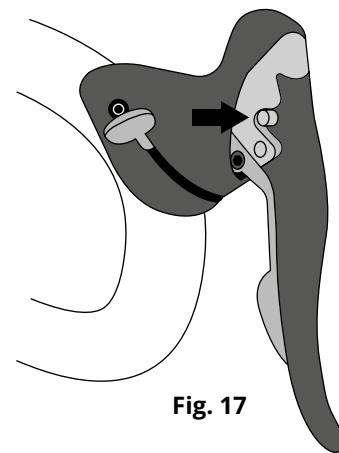

Fig. 17

Most rim brakes have some form of quick-release mechanism to allow the brake pads to clear the tire when a wheel is removed or reinstalled. When the brake quick release is in the open position, the brakes are inoperative. Please contact **BIKE.com** at [cs@bike.com](mailto:cs@bike.com) or call at **1-(877)-755-2453(BIKE)** or ask your dealer for all service to make sure that you understand the way the brake quick release works on your Ebike (see figs. 12, 13, 14 & 15) and check each time to make sure both brakes work correctly before you get on the Ebike.

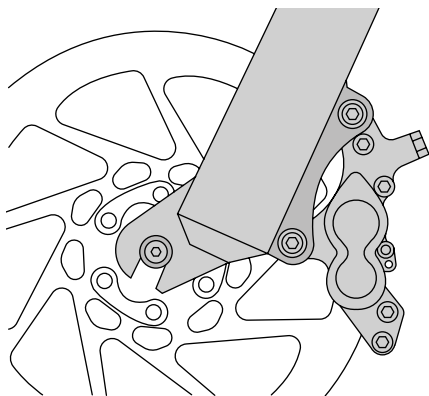

Fig. 13

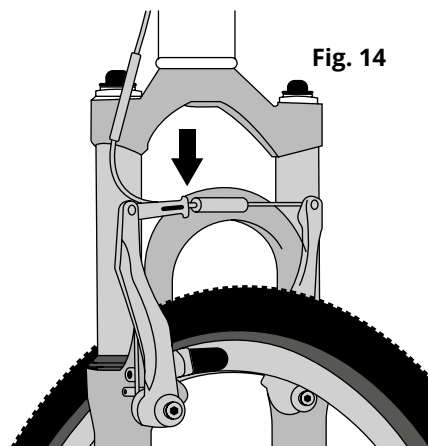

Fig. 14

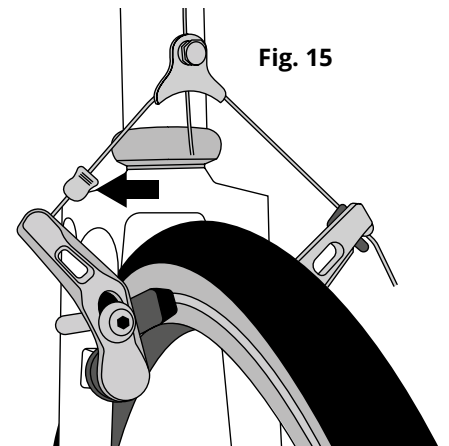

Fig. 15



## 2. How brakes work

The braking action of an Ebike is a function of the friction between the braking surfaces. To make sure that you have maximum friction available, keep your wheel rims and brake pads or the disk rotor and caliper clean and free of dirt, lubricants, waxes, or polishes.

Brakes are designed to control your speed, not just to stop the Ebike. Maximum braking force for each wheel occurs at the point just before the wheel “locks up” (stops rotating) and starts to skid. Once the tire skids, you actually lose most of your stopping force and all directional control. You need to practice slowing and stopping smoothly without locking up a wheel. The technique is called progressive brake modulation. Instead of jerking the brake lever to the position where you think you’ll generate appropriate braking force, squeeze the lever, progressively increasing the braking force. If you feel the wheel begin to lock up, release pressure just a little to keep the wheel rotating just short of lockup. It’s important to develop a feel for the amount of brake lever pressure required for each wheel at different speeds and on different surfaces. To better understand this, experiment a little by walking your Ebike and applying different amounts of pressure to each brake lever, until the wheel locks.

When you apply one or both brakes, the Ebike begins to slow, but your body wants to continue at the speed at which it was going. This causes a transfer of weight to the front wheel (or, under heavy braking, around the front wheel hub, which could send you flying over the handlebars).

A wheel with more weight on it will accept greater brake pressure before lockup; a wheel with less weight will lock up with less brake pressure.

So, as you apply brakes and your weight is transferred forward, you need to shift your body toward the rear of the Ebike, to transfer weight back on to the rear wheel; and at the same time, you need to both decrease rear braking and increase front braking force. This is even more important on descents because descents shift weight forward.

Two keys to effective speed control and safe stopping are controlling wheel lockup and weight transfer. This weight transfer is even more pronounced if your Ebike has a front suspension fork. Front suspension “dips/compresses/dives” under braking, increasing the weight transfer (see also Section 4.F). Practice braking and weight transfer techniques where there is no traffic or other hazards and distractions.

Everything changes when you ride on loose surfaces or in wet weather. It will take longer to stop on loose surfaces or in wet weather. Tire adhesion is reduced, so the wheels have less cornering and braking traction and can lock up with less brake force. Moisture or dirt on the brake pads reduces their ability to grip. The way to maintain control on loose or wet surfaces is to go more slowly.

## D. Shifting gears

Your multi-speed Ebike will have a derailleur drivetrain (see 1. below), an internal gear hub drivetrain (see 2. below) or, in some special cases, a combination of the two.

**⚠ CAUTION: Your Ebike has speed enhancement through a motor, throttle, and additional Ebike components. See Section H. NOTE: added speed will increase need for added braking and awareness. Use of Ebike features is and can be a dangerous and is an increased risk for injury, serious injury or death. Know your bike and your own limitations and always wear a helmet and other appropriate safety gear and know your local laws and regulations.**

### 1. How a derailleur drivetrain works

If your Ebike has a derailleur drivetrain, the gear-changing mechanism will have:

- a rear cassette or freewheel sprocket cluster
- a rear derailleur
- usually, a front derailleur
- one or two shifters
- one, two or three front sprockets called chainrings
- a drive chain

#### a. Shifting Gears

There are several different types and styles of shifting controls: levers, twist grips, triggers, combination shift/brake controls and pushbuttons. Please contact BIKE.com at [cs@bike.com](mailto:cs@bike.com) or call at 1-(877)-755-2453(BIKE) or ask your dealer for all service to explain the type of shifting controls that are on your Ebike, and to show you how they work.

The vocabulary of shifting can be pretty confusing. A downshift is a shift to a “lower” or “slower” gear, one that is easier to pedal. An upshift is a shift to a “higher” or “faster”, harder to pedal gear. What’s confusing is that what’s happening at the front derailleur is the opposite of what’s happening at the rear derailleur (for details, read the instructions on Shifting the Rear Derailleur and Shifting the Front Derailleur below). For example, you can select a gear which will make pedaling easier on a hill (make a downshift) in one of two ways: shift the chain down the gear “steps” to a smaller gear at the front, or up the gear “steps” to a larger gear at the rear. So, at the rear gear cluster, what is called a downshift looks like an upshift. The way to keep things straight is to remember that shifting the chain in towards the centerline of the Ebike is for accelerating and climbing and is called a downshift. Moving the chain out or away from the centerline of the Ebike is for speed and is called an upshift.

Whether upshifting or downshifting, the Ebike derailleur system design requires that the drive chain be moving forward and be under at least some tension. A derailleur will shift only if you are pedaling forward.

**⚠ CAUTION: Never move the shifter while pedaling backward, nor pedal backwards immediately after having moved the shifter. This could jam the chain and cause serious damage to the Ebike.**

## b. Shifting the Rear Derailleur

The rear derailleur is controlled by the right shifter (the side with the crank or if sitting on bike). The function of the rear derailleur is to move the drive chain from one gear sprocket to another. The smaller sprockets on the gear cluster produce higher gear ratios.

Pedaling in the higher gears requires greater pedaling effort but takes you a greater distance with each revolution of the pedal cranks. The larger sprockets produce lower gear ratios. Using them requires less pedaling effort but takes you a shorter distance with each pedal crank revolution. Moving the chain from a smaller sprocket of the gear cluster to a larger sprocket result in a downshift. Moving the chain from a larger sprocket to a smaller sprocket result in an upshift. In order for the derailleur to move the chain from one sprocket to another, the rider must be pedaling forward.

## c. Shifting the Front Derailleur:

The front derailleur, which is controlled by the left shifter, shifts the chain between the larger and smaller chainrings. Shifting the chain onto a smaller chainring makes pedaling easier (a downshift). Shifting to a larger chainring makes pedaling harder (an upshift).

## d. Which gear should I be in?

The combination of largest rear and smallest front gears (FIG 18) is for the steepest hills. The smallest rear and largest front combination is for the greatest speed. It is not necessary to shift gears in sequence. Instead, find the “starting gear” which is right for your level of ability — a gear which is hard enough for quick acceleration but easy enough to let you start from a stop without wobbling — and experiment with upshifting and downshifting to get a feel for the different gear combinations. At first, practice shifting where there are no obstacles, hazards, or other traffic, until you’ve built up your confidence. Learn not to use either the “smallest to smallest” or “largest to largest” gear combinations because they may cause unacceptable stress on the drive train. Learn to anticipate the need to shift, and shift to a lower gear before the hill gets too steep. If you have difficulties with shifting, the problem could be mechanical adjustment. See your dealer for help.

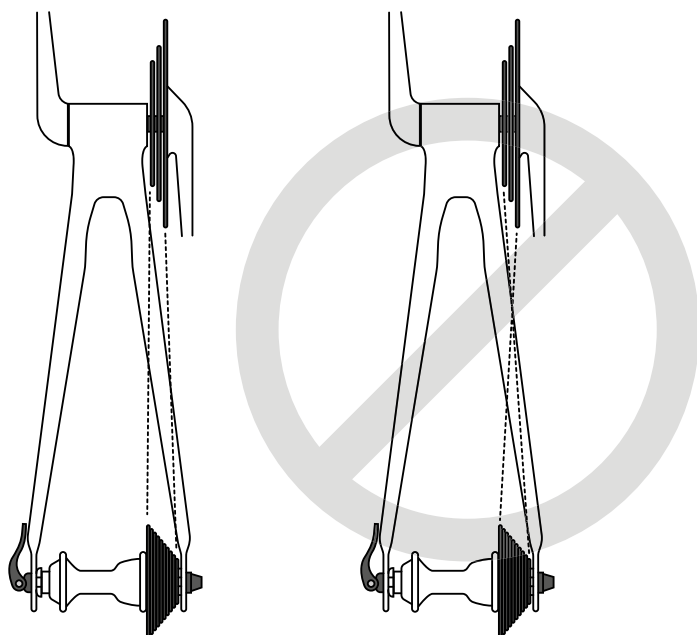

Fig. 18

**⚠ WARNING: Never shift a derailleur onto the largest or the smallest sprocket if the derailleur is not shifting smoothly. The derailleur may be out of adjustment and the chain could jam, causing you to lose control and fall.**

### **e. What if it won't shift gears?**

If moving the shift control, one click repeatedly fails to result in a smooth shift to the next gear chances are that the mechanism is out of adjustment. Take the Ebike to your dealer to have it adjusted.

## **2. How an internal gear hub drivetrain works**

If your Ebike has an internal gear hub drivetrain, the gear changing mechanism will consist of:

- a finite set of speeds (anywhere from three to 18 speeds or more), or possibly an infinitely variable internal gear hub
- one, or sometimes two shifters
- one or two control cables
- one front sprocket called a chainring
- a drive chain

### **a. Shifting internal gear hub gears**

Shifting with an internal gear hub drivetrain is simply a matter of moving the shifter to the indicated position for the desired gear ratio. After you have moved the shifter to the gear position of your choice, ease the pressure on the pedals for an instant to allow the hub to complete the shift.

### **b. Which gear should I be in?**

The numerically lowest gear (1) is for the steepest hills. The numerically largest gear is for the greatest speed.

Shifting from an easier, "slower" gear (like 1) to a harder, "faster" gear (like 2 or 3) is called an upshift. Shifting from a harder, "faster" gear to an easier, "slower" gear is called a downshift. It is not necessary to shift gears in sequence. Instead, find the "starting gear" for the conditions — a gear which is hard enough for quick acceleration but easy enough to let you start from a stop without wobbling — and experiment with upshifting and downshifting to get a feel for the different gears. At first, practice shifting where there are no obstacles, hazards, or other traffic, until you've built up your confidence. Learn to anticipate the need to shift, and shift to a lower gear before the hill gets too steep. If you have difficulties with shifting, the problem could be mechanical adjustment. See your dealer for help.

### **c. What if it won't shift gears?**

If moving the shift control, one click repeatedly fails to result in a smooth shift to the next gear chances are that the mechanism is out of adjustment. Take the Ebike to your dealer to have it adjusted.

## E. Pedals

1. Toe Overlap is when your toe can touch the front wheel when you turn the handlebars to steer while a pedal is in the forward-most position. This is common on small-framed Ebikes and is avoided by keeping the inside pedal up and the outside pedal down when making sharp turns. On any Ebike, this technique will also prevent the inside pedal from striking the ground in a turn.

**NOTE: Changing tire size or pedal crank arm length affects toe overlap.**

**⚠ WARNING: Toe Overlap could cause you to lose control and fall. Please contact BIKE.com at [cs@bike.com](mailto:cs@bike.com) or call at 1-(877)-755-2453(BIKE) or ask your dealer for all service to help you determine if the combination of frame size, crank arm length, pedal design, and shoes you will use results in pedal overlap. Whether you have overlap or not, you must keep the inside pedal up and the outside pedal down when making sharp turns.**

2. Some Ebikes come equipped with pedals that have sharp and potentially dangerous surfaces. These surfaces are designed to add safety by increasing grip between the rider's shoe and the pedal. If your Ebike has this type of high-performance pedal, you must take extra care to avoid serious injury from the pedals' sharp surfaces. Based on your riding style or skill level, you may prefer a less aggressive pedal design, or choose to ride with shin pads. Your dealer can show you a number of options and make suitable recommendations.
3. Toeclips and straps are a means to keep feet correctly positioned and engaged with the pedals. The toeclip positions the ball of the foot over the pedal spindle, which gives maximum pedaling power. The toe strap, when tightened, keeps the foot engaged throughout the rotation cycle of the pedal. While toeclips and straps give some benefit with any kind of shoe, they work most effectively with cycling shoes designed for use with toeclips. Your dealer can explain how toeclips and straps work. Shoes with deep treaded soles or welts which might make it more difficult for you to insert or remove your foot should not be used with toeclips and straps.

**⚠ WARNING: Getting into and out of pedals with toeclips and straps requires skill which can only be acquired with practice. Until it becomes a reflex action, the technique requires concentration that can distract your attention and cause you to lose control and fall. Practice the use of toeclips and straps where there are no obstacles, hazards, or traffic. Keep the straps loose, and don't tighten them until your technique and confidence in getting in and out of the pedals warrants it. Never ride in traffic with your toe straps tight.**

4. Clipless pedals (sometimes called “step-in pedals”) are another means to keep feet securely in the correct position for maximum pedaling efficiency. They have a plate, called a “cleat,” on the sole of the shoe, which clicks into a mating spring-loaded fixture on the pedal. They only engage or disengage with a very specific motion that must be practiced until it becomes instinctive. Clipless pedals require shoes and cleats which are compatible with the make and model pedal being used.

Many clipless pedals are designed to allow the rider to adjust the amount of force needed to engage or disengage the foot. Follow the pedal manufacturer’s instructions, or please contact **BIKE.com** at **cs@bike.com** or call at **1-(877)-755-2453(BIKE)** or ask your dealer for all service to show you how to make this adjustment. Use the easiest setting until engaging and disengaging becomes a reflex action, but always make sure that there is sufficient tension to prevent unintended release of your foot from the pedal.

**⚠ WARNING: Clipless pedals are intended for use with shoes specifically made to fit them and are designed to firmly keep the foot engaged with the pedal. Do not use shoes which do not engage the pedals correctly.**

Practice is required to learn to engage and disengage the foot safely. Until engaging and disengaging the foot becomes a reflex action, the technique requires concentration which can distract your attention and cause you to lose control and fall. Practice engaging and disengaging clipless pedals in a place where there are no obstacles, hazards, or traffic; and be sure to follow the pedal manufacturer’s setup and service instructions. If you do not have the manufacturer’s instructions, see your dealer, or contact the manufacturer.

## **F. eBike Suspension**

Many Ebikes are equipped with suspension systems. There are many different types of suspension systems — too many to deal with individually in this Manual. If your Ebike has a suspension system of any kind, be sure to read and follow the suspension manufacturer’s setup and service instructions. If you do not have the manufacturer’s instructions, see your dealer, or contact the manufacturer

**⚠ WARNING: Failure to maintain, check and properly adjust the suspension system may result in suspension malfunction, which may cause you to lose control and fall.**

If your Ebike has suspension, the increased speed you may develop also increases your risk of injury. For example, when braking, the front of a suspended Ebike dips, compresses or dives. You could lose control and fall if you do not have experience with this system. Learn to handle your suspension system safely. See also Section 4.C.

**⚠ WARNING: Changing suspension adjustment can change the handling and braking characteristics of your Ebike. Never change suspension adjustment unless you are thoroughly familiar with the suspension system manufacturer's instructions and recommendations, and always check for changes in the handling and braking characteristics of the Ebike after a suspension adjustment by taking a careful test ride in a hazard-free area.**

Suspension can increase control and comfort by allowing the wheels to better follow the terrain. This enhanced capability may allow you to ride faster; but you must not confuse the enhanced capabilities of the Ebike with your own capabilities as a rider. Increasing your skill will take time and practice. Proceed carefully until you have learned to handle the full capabilities of your Ebike.

**⚠ WARNING: Not all Ebikes can be safely retrofitted with some types of suspension systems. Before retrofitting an Ebike with any suspension, check with the Ebikes manufacturer to make sure that what you want to do is compatible with the Ebikes design. Failing to do so can result in catastrophic frame failure.**

## G. Tires and Tubes

**⚠ WARNING: Some Ebikes intended for competition are fitted with tires that are glued on to specially made rims. These are called "sew-up" or "tubular" tires. Properly mounting these tires requires specialized knowledge and skills. Please contact BIKE.com at [cs@bike.com](mailto:cs@bike.com) or call at 1-(877)-755-2453(BIKE) or ask your dealer for all service to teach you how to mount tubulars before you attempt it on your own. An incorrectly installed tubular tire can come off the rim, causing you to lose control and fall.**

### 1. Tires

Ebike tires are available in many designs and specifications, ranging from general-purpose designs to tires designed to perform best under very specific weather or terrain conditions. If, once you've gained experience with your new Ebike, you feel that a different tire might better suit your riding needs, your dealer can help you select the most appropriate design.

The size, pressure rating, and on some high-performance tires the specific recommended use, are marked on the sidewall of the tire (see FIG 19). The part of this information which is most important to you is Tire Pressure. But some wheel rim manufacturers also specify maximum tire pressure with a label on the rim.

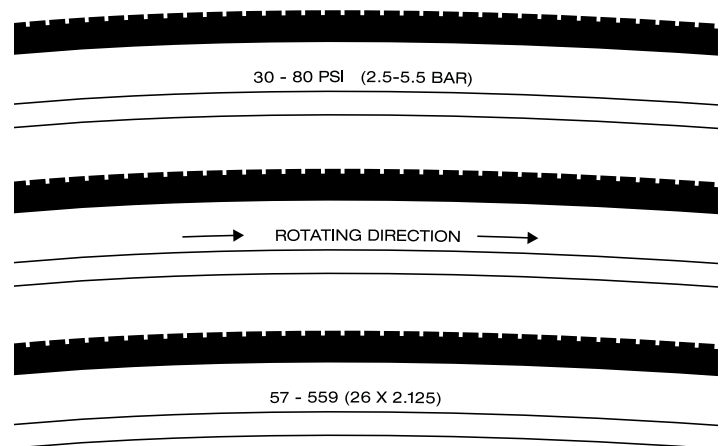

Fig. 19

**⚠️ WARNING: Never inflate a tire beyond the maximum pressure marked on the tire's sidewall or the wheel rim. If the maximum pressure rating for the wheel rim is lower than the maximum pressure shown on the tire, always use the lower rating. Exceeding the recommended maximum pressure may blow the tire off the rim or damage the wheel rim, which could cause damage to the Ebike and injury to the rider and bystanders.**

The best and safest way to inflate an Ebike tire to the correct pressure is with an Ebike pump that has a built-in pressure gauge.

**⚠️ WARNING: There is a safety risk in using gas station air hoses or other air compressors. They are not made for Ebike tires. They move a large volume of air very rapidly and will raise the pressure in your tire very rapidly, which could cause the tube to explode.**

Tire pressure is given either as maximum pressure or as a pressure range. How a tire performs under different terrain or weather conditions depends largely on tire pressure. Inflating the tire to near its maximum recommended pressure gives the lowest rolling resistance; but also produces the harshest ride. High pressures work best on smooth, dry pavement.

Very low pressures, at the bottom of the recommended pressure range, give the best performance on smooth, slick terrain such as hard-packed clay, and on deep, loose surfaces such as deep, dry sand.

Tire pressure that is too low for your weight and the riding conditions can cause a puncture of the tube by allowing the tire to deform sufficiently to pinch the inner tube between the rim and the riding surface. This may also result in rim damage.

**⚠️ CAUTION: Pencil type automotive tire gauges can be inaccurate and should not be relied upon for consistent, accurate pressure readings. Instead, use a high-quality dial or digital gauge.**

Please contact **BIKE.com** at [cs@bike.com](mailto:cs@bike.com) or call at 1-(877)-755-2453(BIKE) or ask your dealer for all service to recommend the best tire pressure for the kind of riding you will most often do, and have the dealer inflate your tires to that pressure. Then, check inflation as described in Section 1.C so you'll know how correctly inflated tires should look and feel when you don't have access to a gauge. Some tires may need to be brought up to pressure every week or two, so it is important to check your tire pressures before every ride.

Some special high-performance tires have unidirectional treads: their tread pattern is designed to work better in one direction than in the other. The sidewall marking of a unidirectional tire will have an arrow showing the correct rotation direction. If your Ebike has unidirectional tires, be sure that they are mounted to rotate in the correct direction.



## 2. Tire Valves

There are primarily two kinds of Ebike tire valves: The Schrader Valve and the Presta Valve. The Ebike pump you use must have the fitting appropriate to the valve stems on your Ebike. The Schrader valve (FIG 20.A) is like the valve on a car tire. To inflate a Schrader valve tire, remove the valve cap and clamp the pump fitting onto the end of the valve stem. To let air out of a Schrader valve, depress the pin in the end of the valve stem with the end of a key or other appropriate object.

The Presta valve (FIG 20.B) has a narrower diameter and is only found on Ebike tires. To inflate a Presta valve tire using a Presta headed Ebike pump, remove the valve cap; unscrew (counterclockwise) the valve stem lock nut; and push down on the valve stem to free it up. Then push the pump head on to the valve head and inflate. To inflate a Presta valve with a Schrader pump fitting, you'll need a Presta adapter (available at your Ebike shop) which screws on to the valve stem once you've freed up the valve. The adapter fits into the Schrader pump fitting. Close the valve after inflation. To let air out of a Presta valve, open up the valve stem lock nut and depress the valve stem.

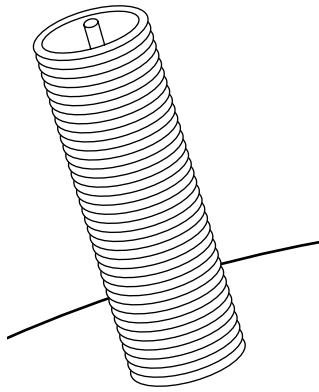

Fig. 20.A

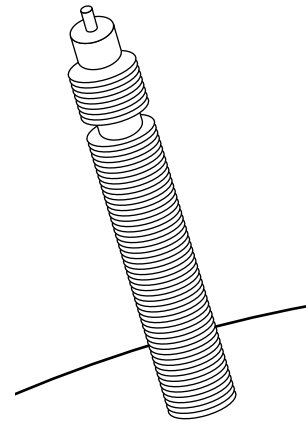

Fig. 20.B

**⚠ WARNING: We highly recommend that you carry a spare inner tube when you ride your Ebike, unless the Ebike is fitted with tubeless tires. Patching a tube is an emergency repair. If you do not apply the patch correctly or apply several patches, the tube can fail, resulting in possible tube failure, which could cause you to lose control and fall. Replace a patched tube as soon as possible.**

## H. eBike Components

**⚠ CAUTION:** Your Ebike has speed enhancement through a motor, throttle, and additional Ebike components. **NOTE:** added speed will increase need for added braking and awareness. Use of Ebike features is and can be a dangerous and is an increased risk for injury, serious injury or death. Know your bike and your own limitations and always wear a helmet and other appropriate safety gear and know your local laws and regulations.

### 1. Battery

**⚠ CAUTION:** Your Ebike has a lithium-ion battery. Please note that if you see any swelling, leaking, or poor performance please contact us immediately at [BIKE.com](mailto:BIKE.com) [cs@bike.com](mailto:cs@bike.com) or call at 1-(877)-755-2453(BIKE) or ask your dealer for help and support. If your battery is hot or is on fire, please contact EMERGENCY SUPPORT IMMEDIATELY.

**⚠ WARNING:** Your battery has connectors inside the chamber on your bike. Make sure the connectors on your bike and within the battery are not bent or damaged in any way. Some specifics steps could be different on specific models so please reference specific model details.

#### a. To Remove Battery

Please follow the following steps to insure proper removal of your battery. (FIG 21.A-21.D)

**DO NOT store your battery inside or outside in temperatures below 50F (10C) or above 86F(30C)**

1. Insert key and unlock the battery
2. Bottom of battery will be able to be removed out
3. Remove battery completely and inspect battery and bike connectors to confirm in good shape

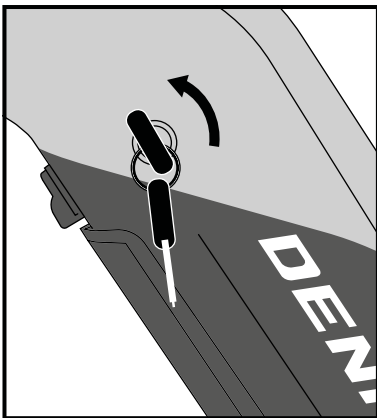

Fig. 21.A

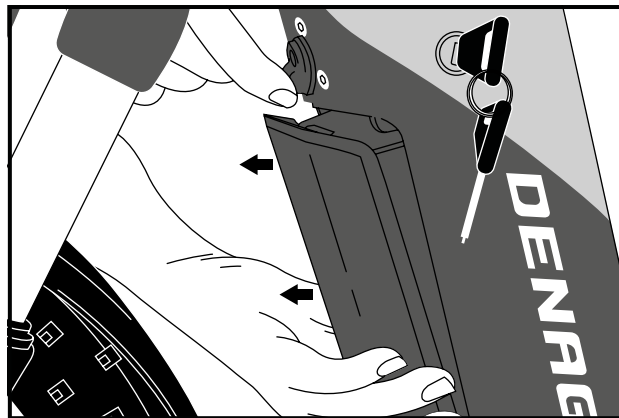

Fig. 21.B

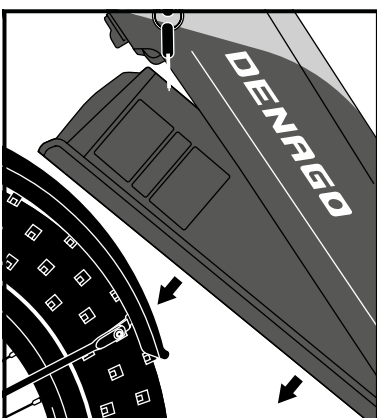

Fig. 21.C

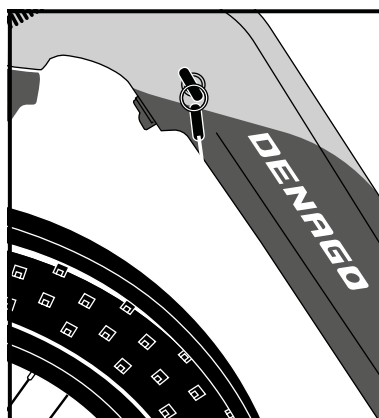

Fig. 21.D

## b. To Install Battery

Please follow the following steps to insure proper installation of your battery. (FIG 22.A-22.D)

-Do a visual and touch inspection. Make sure you do not have any swelling, heat, or leaking. If so, do not install and contact us immediately at **BIKE.com** at **cs@bike.com** or call at **1-(877)-755-2453(BIKE)** or contact your local dealer

1. Ensure connectors on your bike and on your battery are in good working condition
2. Insert bottom of battery into the bottom section of the battery chamber on your bicycle. The connectors should engage
3. Lift top of battery into the top of the chamber until you hear a click

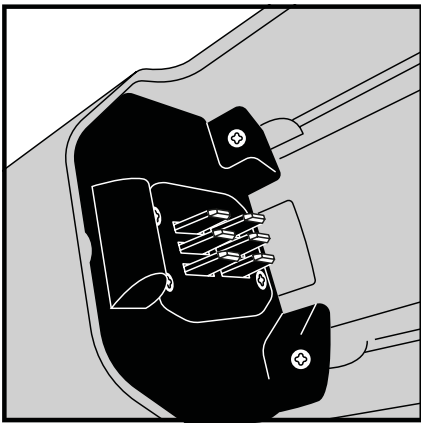

Fig. 22.A

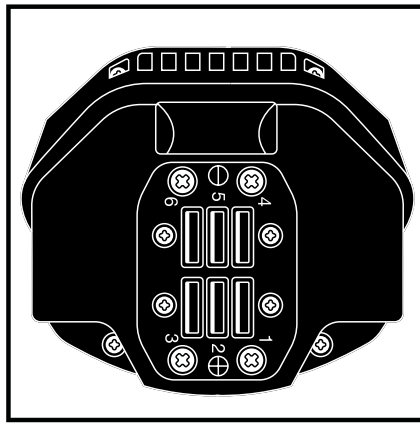

Fig. 22.B

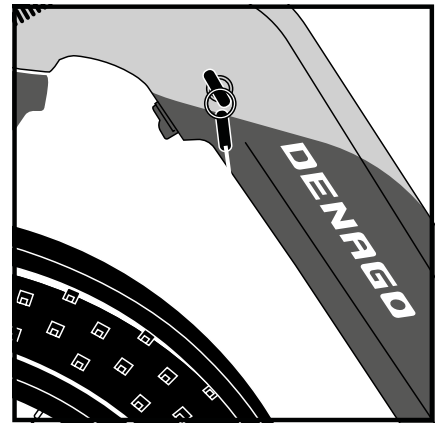

Fig. 22.C

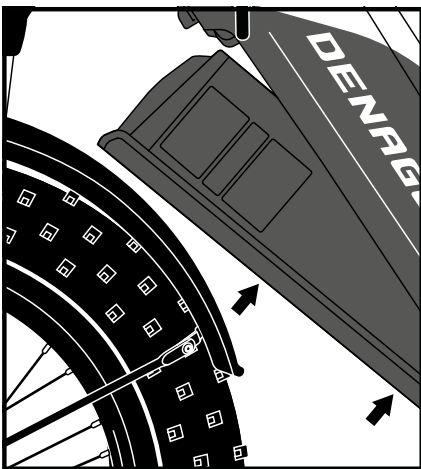

Fig. 22.D

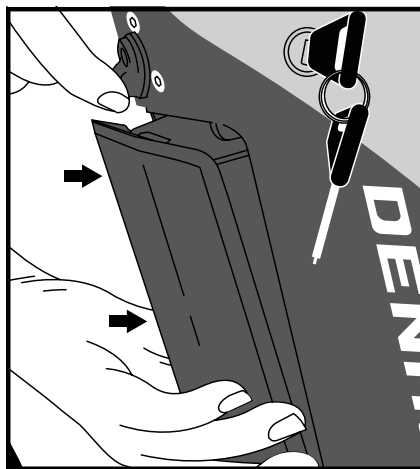

Fig. 22.E

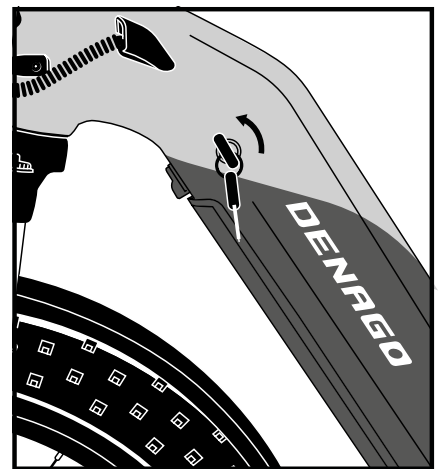

Fig. 22.F

## To Charge Battery - (FIG 23.A-23.D)

1. Turn battery to OFF position
  2. Locate port and insert charger
  3. Plug charger into wall outlet into a 110volt plug
  4. Confirm Light on Battery and Charger  
(will be RED when charging and turn GREEN when charged)
- Always charge your battery in a temperature between 50F to 86F (10C- 30C)
  - It will take between 3 and 8 hours for fully charge your battery depending on starting point
  - Inspect your charger to make sure no damage or frayed wires.
- If so, DO NOT USE and seek help from the Manufacturer

**⚠ CAUTION: Always charge your battery in a clean, clear, dry and safe space, away from direct sunlight. Do not cover or leave unattended. Never charge for more than 12 hours at a time.**



Fig. 23.A

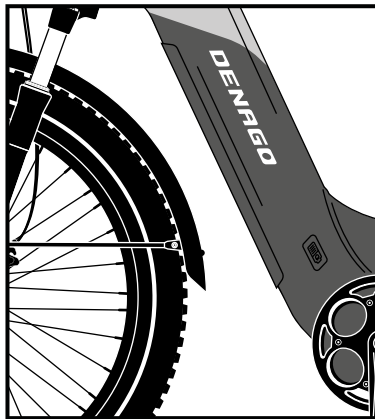

Fig. 23.B

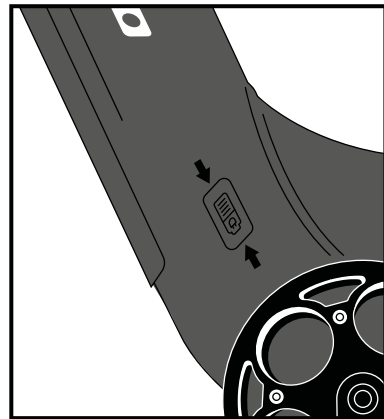

Fig. 23.C

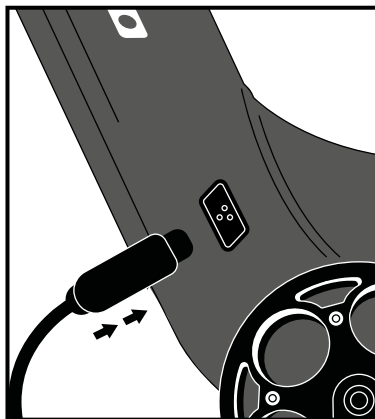

Fig. 23.D

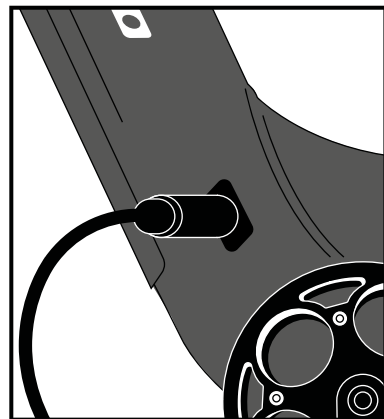

Fig. 23.E

**⚠ WARNING: Only use factory supplied battery and battery charger. Failure to do so could result in damage, fire, serious injury or death. Keep battery and charger away from children.**

### c. Long Term Battery Storage

**If storing your bike for longer than 2 weeks at a time without riding and charging your battery, please follow these battery health and longevity**

1. Charge or discharge your battery to approximately 75% level
2. Remove the battery from the bike frame
3. Store the battery in a dry cool environment out of the sun. **Ideally 50F to 86F (10C-30C)**
4. Check the battery periodically and charge or discharge as needed to maintain an approximate 75% charge level

**⚠️ WARNING: Do not ever cover the battery or charger. This could cause overheating and potential fire.**

**⚠️ WARNING: DO NOT open the battery housing. You will void all warranties and potential for serious injury and or death could occur.**

### d. Battery Disposal

Seek information from your local area on proper lithium-ion battery disposal or contact **BIKE.com** at [cs@bike.com](mailto:cs@bike.com) or call at 1-(877)-755-2453(BIKE) or ask your dealer for information. Failure to follow local government rules for proper lithium-ion battery disposal could result in injury or death due to fires, explosions, and or severe burns or electrocutions. Dispose in a responsible and recycling way.

## 2. Motor

Ebikes have many different styles of motors. Please see your Ebike Spec Guide for full details of what your specific bicycle has. Hub motor (FIG 24)

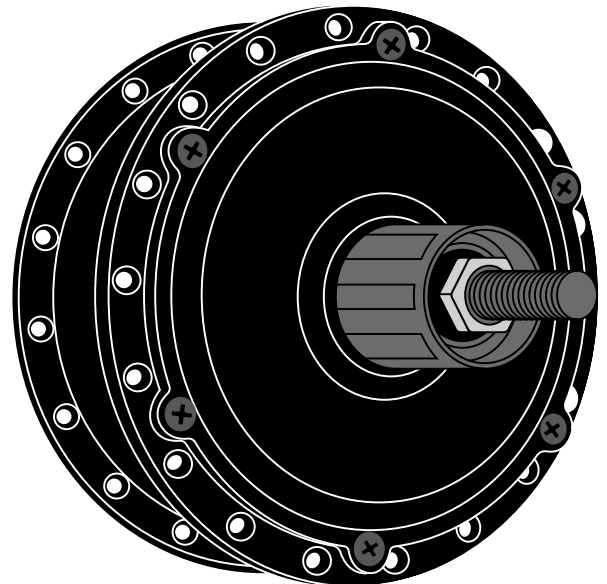

Fig. 24

### 3. Throttle

The throttle is your controller for speed/propelling you on your Ebike. Your Ebike will likely have one of two options. Please be aware and confident with your throttle/controller. If you have any questions, please contact **BIKE.com** at [cs@bike.com](mailto:cs@bike.com) or call at 1-(877)-755-2453(BIKE) or ask your dealer for information

- a. Thumb Throttle: are operated using your thumb (FIG 25), where you push down on a small, spring-loaded thumb-size paddle to engage the motor. The more you push down, the faster the bike will go.
- b. Twist Throttle: can include the full hand grip or half the grip, are twisted downward to activate the motor, similar to throttles you find on scooters and motorcycles.

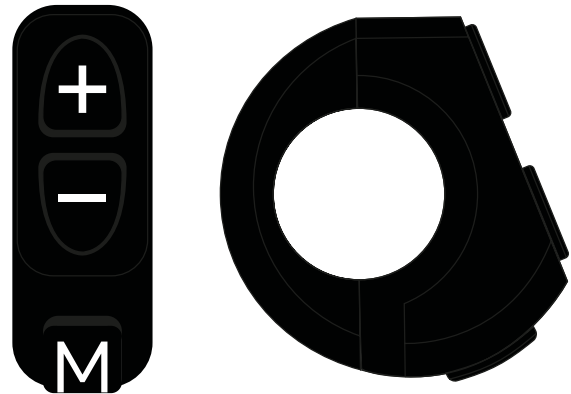

Fig. 25

**⚠ CAUTION: Be careful with features and functions while riding your bike. All features and adjustments can be made while in a non-riding situation. Any adjustments or changes made while riding can be dangerous and could cause injury or death.**

### 4. Monitor

- a. The monitor (FIG 26) is connected in a number of ways to your eBike. It interfaces with the HMI to adjust your PAS levels, advises if you have a problem with your brakes and also tracks a number of great features. Like speed, distance, MAX speed, battery level etc. The following will show you how to confirm and make needed adjustments.



**STEP 1** – Press and hold **M (MODE)** button until screen turns to either MAX speed or AVE speed.

**STEP 2** – Press and hold **+ - (UP/Down)** simultaneously for 2-4 seconds until screen flashes and goes to setting interface. You have 4 settings, use the **+ -** to toggle thru each screen and the **M** to move to the next setting.

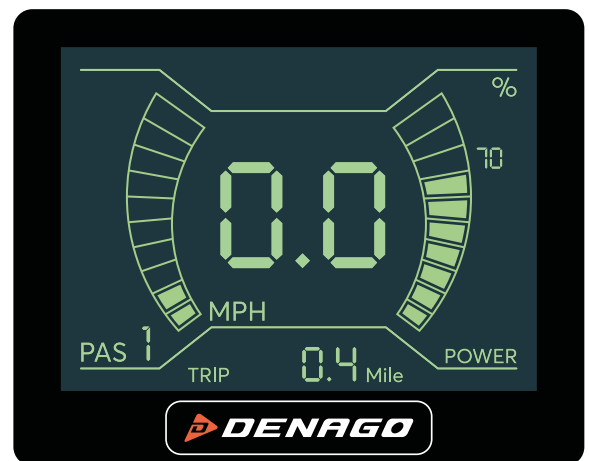

Fig. 26



**SETTING 1 - inCH:** Wheel size setting.  
Your Denago City 1.0 is **27.5**.



**SETTING 2 - LS:** Limited Speed.  
This is your max speed setting.



**SETTING 3 - BL:** this is screen brightness.  
You have 3 levels.

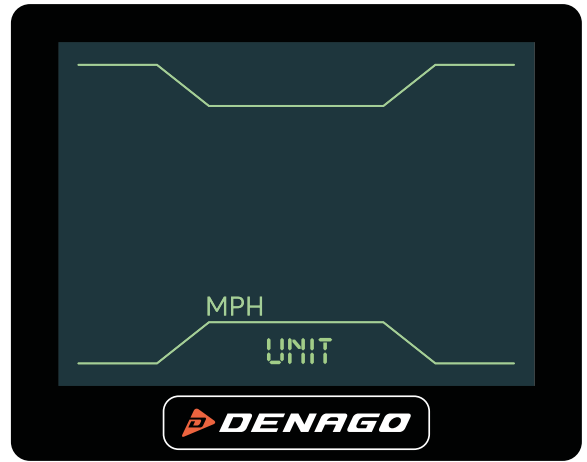

**SETTING 4 - unit:** this is the speed  
and distance setting MPH or KPH.

**⚠ WARNING: Please perform a safety check and make sure to adjust your MAX speed to a comfortable and confident speed. Enjoy the Ride.**

### b. Pedal Assist Speed Adjustments

The following instructions will outline how you set the MAX Speed in Pedal Assist (PAS) level 5. Once this is set it will adjust each of the other levels by a preset percentage.

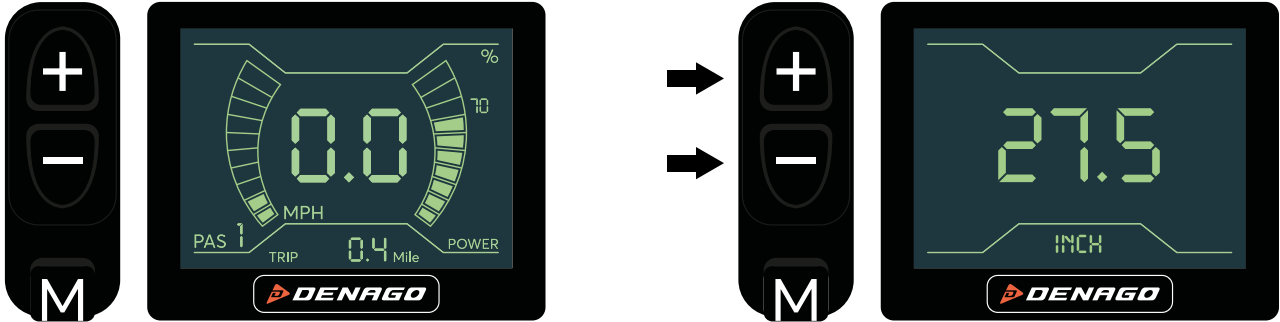

**STEP 0** – Locate the HMI - Human Machine Interface.

**STEP 1** – Press **M MODE** button to engage screen.

**STEP 2** – Press **+ - (UP/Down)** simultaneously for 2-4 seconds until screen flashes and goes to setting interface.

**STEP 3** – First screen to pop up is wheel size. Press **M MODE** to go to next screen.



**STEP 4** – Limited Speed mode - (**LS**) this is where you can adjust MAX speed. Use the **+ - (UP/Down)** to adjust MAX limit. Your range is **28 -11 mph** as the lowest limit.

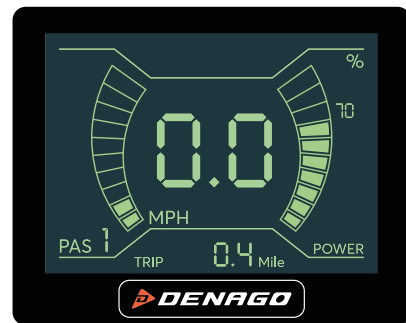

**STEP 5** – Press **M (MODE)** for 2 seconds to return to main screen. You are ready to ride.



## b. Pedal Assist Speed Adjustments (continued)

Denago City 1.0 PAS (Pedal Assist System) comes with the ability to set your MAX speed while also adjusting your PAS level speeds.

**Custom Pedal Assist Settings** - The rider is able to adjust the MAX speed setting with 18 micro adjustments

- 28mph MAX down to 11mph
- With adjustment it will proportional adjust each of the other PAS levels accordingly (chart included)
- Adjustment made with 4 easy steps
- Easy to do anywhere
- Allows for better rider comfort, control, confidence, and safety
- Assist in better pedal engagement when rider preferred settings are achieved

MPH	PAS1	PAS2	PAS3	PAS4	PAS5
28	16.8	19.6	22.4	25.2	28
27	16.2	18.9	21.6	24.3	27
26	15.6	18.2	20.8	23.4	26
25	15	17.5	20	22.5	25
24	14.4	16.8	19.2	21.6	24
23	13.8	16.1	18.4	20.7	23
22	13.2	15.4	17.6	19.8	22
21	12.6	14.7	16.8	18.9	21
20	12	14	16	18	20
19	11.4	13.3	15.2	17.1	19
18	10.8	12.6	14.4	16.2	18
17	10.2	11.9	13.6	15.3	17
16	9.6	11.2	12.8	14.4	16
15	9.1	10.5	12	13.5	15
14	8.4	9.8	11.2	12.6	14
13	7.8	9.1	10.4	11.7	13
12	7.2	8.4	9.6	10.8	12
11	6.6	7.7	8.8	9.9	11

### c. Passcode Monitor Settings

Your monitor has many unique settings. The following will share how to use the PASSCODE SECURITY settings and well as turn this feature on and off.

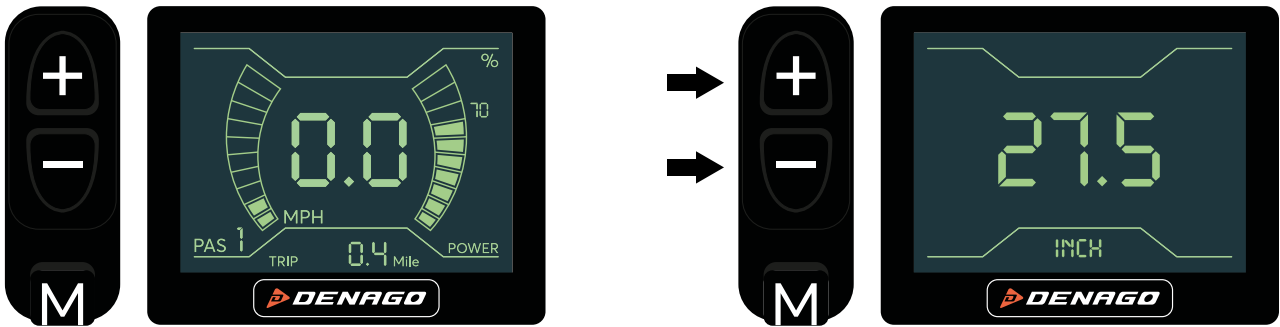

**STEP 1** – Press **M MODE** button until screen turns to either MAX speed or AVE speed.

**STEP 2** – Press **+ - (UP/Down)** simultaneously for 2-4 seconds until screen flashes and goes to setting interface. You have 4 settings.

Use the **+ -** to toggle thru each screen and the **M** to move to the next setting. Scroll through the settings until you get to **PASSCODE** - at this point you can either set your code.

**NOTE** please write this down and remember this. Your monitor can be reprogrammed but it will require speaking to an agent. If you do not want this feature simply turn it off. You do this by moving the **+ -** to your desired preference. Press the **M** button to return to the main screen.

## 5. Harness

This is the wiring/cabling that connects your monitor, throttle to the battery and the motor. (FIG 27.A-27.C)

**⚠ WARNING: Make sure the wires/cables are secure at all ends and no exposed internal wiring is showing. If exposed wiring is showing DO NOT RIDE your Ebike and contact us at BIKE.com at cs@bike.com or call at 1-(877)-755-2453(BIKE) or ask your dealer for support.**

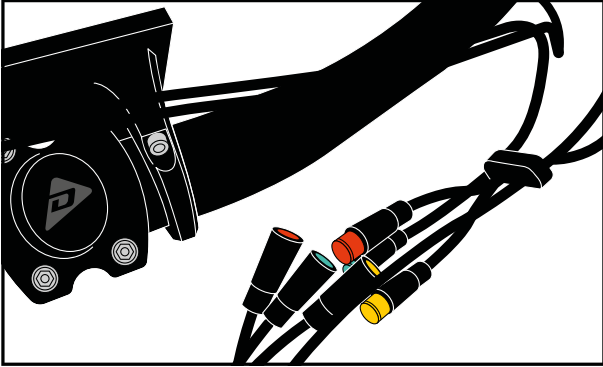

Fig. 27.A

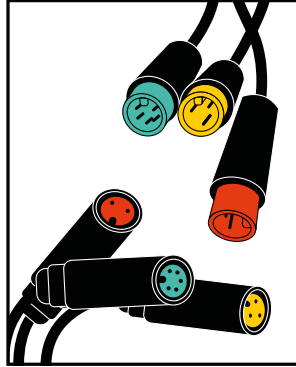

Fig. 27.B

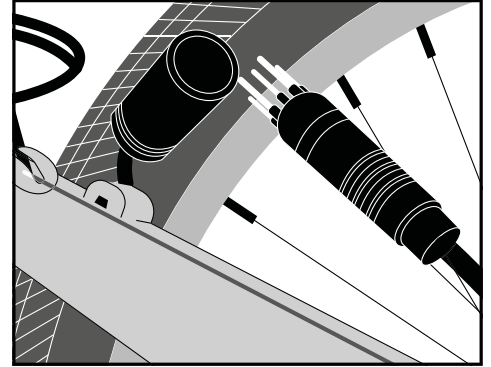

Fig. 27.C

## 6. Riding Range of your eBike

Range of your battery life and Ebike assist on your ride has many variables.

Most importantly is how much pedaling are you willing to do? Also, the terrain, weather, wind, rider weight and how much are carrying play an impact on possible distance. The following is a very basic guide to help you project your ride. Please see your specific bike reference for more information or our web site for more real-world results

Expected Range	Operating Condition(s)
32 km (20 mi)	Hilly Terrain Heavy Payload Windy High Pedal Assist Level/ High Throttle Use Light Pedaling
48 km (30 mi)	Flat Terrain Normal Payload Not Windy Medium Pedal Assist Level/ Moderate Throttle Use Light Pedaling
64 km (40 mi)	Flat Terrain Normal Payload Not Windy Low Pedal Assist Level/ Minimal Throttle Use Moderate to Heavy Pedaling

**⚠ CAUTION: Your Ebike has speed enhancement through a motor, throttle, and additional Ebike components. NOTE: added speed will increase need for added braking and awareness. Use of Ebike features is and can be a dangerous and is an increased risk for injury, serious injury or death. Know your bike and your own limitations and always wear a helmet and other appropriate safety gear and know your local laws and regulations.**

## 5. SERVICE

**⚠ WARNING: Technological advances have made Ebikes and Ebike components more complex, and the pace of innovation is increasing. It is impossible for this manual to provide all the information required to properly repair and/or maintain your Ebike. In order to help minimize the chances of an accident and possible injury, it is critical that you have any repair or maintenance that is not specifically described in this manual performed by your dealer. Equally important is that your individual maintenance requirements will be determined by everything from your riding style to geographic location. Consult your dealer for help in determining your maintenance requirements.**

**⚠ WARNING: Many Ebike service and repair tasks require special knowledge and tools. Do not begin any adjustments or service on your Ebike until you have learned from your dealer how to properly complete them. Improper adjustment or service may result in damage to the Ebike or in an accident which can cause serious injury or death.**

If you want to learn to do major service and repair work on your Ebike:

1. Please contact **BIKE.com** at **cs@bike.com** or call at **1-(877)-755-2453(BIKE)** or ask your dealer for copies of the manufacturer's installation and service instructions for the components on your Ebike or contact the component manufacturer.
2. Please contact **BIKE.com** at **cs@bike.com** or call at **1-(877)-755-2453(BIKE)** or ask your dealer to recommend a book on Ebike repair.
3. Please contact **BIKE.com** at **cs@bike.com** or call at **1-(877)-755-2453(BIKE)** or ask your dealer for all service about the availability of Ebike repair courses in your area.

We recommend that you please contact **BIKE.com** at **cs@bike.com** or call at **1-(877)-755-2453(BIKE)** or ask your dealer for all service to check the quality of your work the first time you work on something and before you ride the Ebike, just to make sure that you did everything correctly. Since that will require the time of a mechanic, there may be a modest charge for this service.

We also recommend that you please contact **BIKE.com** at **cs@bike.com** or call at **1-(877)-755-2453(BIKE)** or ask your dealer for all service guidance on what spare parts, such as tires, inner tubes, light bulbs, batteries, patch kit, lubricants etc. it would be appropriate for you to have once you have learned how to replace such parts when they require replacement

## A. Service Intervals

Some service and maintenance can and should be performed by the owner and require no special tools or knowledge beyond what is presented in this manual.

The following are examples of the type of service you should perform yourself. All other service, maintenance and repair should be performed in a properly equipped facility by a qualified Ebike mechanic using the correct tools and procedures specified by the manufacturer.

1. Break-in Period: Your Ebike will last longer and work better if you break it in before riding it hard. Control cables and wheel spokes may stretch or “seat” when a new Ebike is first used and may require readjustment by your dealer. Your Mechanical Safety Check (Section 1.D) will help you identify some things that need readjustment. But even if everything seems fine to you, it’s best to take your Ebike back to the dealer for a checkup. Dealers typically suggest you bring the Ebike in for a 30-day checkup. Another way to judge when it’s time for the first checkup is to bring the Ebike in after three to five hours of hard off-road use, or about 10 to 15 hours of on-road or more casual off-road use. But if you think something is wrong with the Ebike, take it to your dealer before riding it again.
2. Before every ride: Mechanical Safety Check (Section 1.D)
3. After every long or hard ride; if the Ebike has been exposed to water or grit; or at least every 100 miles: Clean the Ebike and lightly lubricate the chain’s rollers with a good quality Ebike chain lubricant. Wipe off excess lubricant with a lint-free cloth. Lubrication is a function of climate. Talk to your dealer about the best lubricants and the recommended lubrication frequency for your area.
4. After every long or hard ride or after every 10 to 20 hours of riding:
  - Squeeze the front brake and rock the Ebike forward and back. Everything feel solid? If you feel a clunk with each forward or backward movement of the Ebike, you probably have a loose headset. Have your dealer check it.
  - Lift the front wheel off the ground and swing it from side to side. Feel smooth? If you feel any binding or roughness in the steering, you may have a tight headset. Have your dealer check it.
  - Grab one pedal and rock it toward and away from the centerline of the Ebike; then do the same with the other pedal. Anything feel loose? If so, have your dealer check it.
  - Take a look at the brake pads. Are they worn or not hitting the wheel rim squarely? Time to have the dealer adjust or replace them.
  - Carefully check the control cables and cable housings. Any rust? Kinks? Fraying? If so, have your dealer replace them.
  - Squeeze each adjoining pair of spokes on either side of each wheel between your thumb and index finger. Do they all feel about the same? If any feel loose, have your dealer check the wheel for tension and trueness.
  - Check the tires for excess wear, cuts, or bruises. Have your dealer replace them if necessary.
  - Check the wheel rims for excess wear, dings, dents, and scratches. Consult your dealer if you see any rim damage.
  - Check to make sure that all parts and accessories are still secure and tighten any that are not.

- Check the frame, particularly in the area around all tube joints; the handlebars; the stem; and the seat post for any deep scratches, cracks, or discoloration. These are signs of stress-caused fatigue and indicate that a part is at the end of its useful life and needs to be replaced. See also Appendix C.
5. Disc brakes require a different set of inspection steps. Check for these issues before every ride:
- Pads rubbing on rotors.
  - Worn out pads (which can lead to over-extended pistons).
  - Pistons that are stuck and/or won't retract fully.
  - Disc rotors that are bent and need straightening by the dealer.
  - Hydraulic brakes that feel "sponge-y" and/or levers that can be depressed all the way to the grips w/o generating adequate stopping power (due to trapped air and/or leaks).
6. Ebike Specific Service Review
- Battery- always do a visual and touch inspection to ensure no overheating, leaking or expansion. Always charge battery to 100% prior to any ride.
  - Motor- Confirm no damage
  - Throttle- confirm this is secure on the handlebar and moves freely and does not have any stiction of friction
  - Monitor – confirm this is charged and is free of any damage or cracks and is functioning properly
  - Cable Harness- visual and touch inspection to ensure all ends are connected correctly and no exposed sections are showing.

**⚠ WARNING: Like any mechanical device, an Ebike and its components are subject to wear and stress. Different materials and mechanisms wear or fatigue from stress at different rates and have different life cycles. If a component's life cycle is exceeded, the component can suddenly and catastrophically fail, causing serious injury or death to the rider.**

**Scratches, cracks, fraying, and discoloration are signs of stress-caused fatigue and indicate that a part is at the end of its useful life and needs to be replaced. While the materials and workmanship of your Ebike or of individual components may be covered by a warranty for a specified period of time by the manufacturer, this is no guarantee that the product will last the term of the warranty. Product life is often related to the kind of riding you do and to the treatment to which you submit the Ebike. The Ebikes warranty is not meant to suggest that the Ebike cannot be broken or will last forever. It only means that the Ebike is covered subject to the terms of the warranty. Please be sure to read Appendix B, Intended Use of your Ebike and Appendix C, the lifespan of your Ebike and its components.**

7. As required: If either brake lever fails the Mechanical Safety Check (Section 1.D), don't ride the Ebike. Have your dealer check the brakes. If the chain won't shift smoothly and quietly from gear to gear, the derailleur is out of adjustment. See your dealer.
8. 8. Every 25 hours of riding: Take your Ebike to your dealer for a complete checkup.

**⚠ CAUTION:** Your Ebike has speed enhancement through a motor, throttle, and additional Ebike components. See Section H. **NOTE:** added speed will increase need for added braking and awareness. Use of Ebike features is and can be a dangerous and is an increased risk for injury, serious injury or death. Know your bike and your own limitations and always wear a helmet and other appropriate safety gear and know your local laws and regulations.

## **B. If your Ebike sustains an impact:**

First, check yourself for injuries, and take care of them as best you can. Seek medical help if necessary.

Next, check your Ebike for damage.

After any crash, take your Ebike to your dealer for a thorough check. Carbon composite components, including frames, wheels, handlebars, stems, cranksets, brakes, etc. which have sustained an impact must not be ridden until they have been disassembled and thoroughly inspected by a qualified mechanic. *See also Appendix C, Lifespan of your Ebike and its components.*

**⚠ WARNING:** A crash or other impact can put extraordinary stress on Ebike components, causing them to fatigue prematurely. Components suffering from stress fatigue can fail suddenly and catastrophically, causing loss of control, serious injury or death.

# APPENDIX A

## Teaching Your Child, the Rules

In addition to The Basics (Section 2.A.), Riding Safely (Section 2.B.), Off Road Safety (Section 2.C.), Wet Weather Riding (Section 2.D.), Night Riding (Section 2.E.), and Downhill, Stunt and Competition Biking (Section 2.F. and Appendix B), kids need to be taught ... and to have frequently reinforced ... the following rules and lessons which adults are already expected to know. We urge you to take the time to familiarize yourself with these rules and to teach them to your child before you let your child ride unsupervised.

### 1. Rules

- No playing in the road or in the street.
- No riding on busy streets.
- No riding at dawn, dusk or at night.
- Stop for all STOP signs.
- Ride on the right of traffic.

### 2. Lessons

The lessons that follow relate to some of the most common real situations that children encounter when riding their Ebikes. Go over these situations with your child and make sure the lesson objective is accomplished

#### a. Driveway Rideout

When a youngster rides out of the driveway and is struck by a car, that is called a ride out accident.

**What can you do?** First, realize the danger of your own driveway. If there are obstructions to the view of passing motorists (like bushes or trees), trim them back. You might park your car in front of the driveway if local ordinance permits. This way, your child can't use the driveway as a launching pad. But the most important thing you can do is teach your child about driveway safety. Take your child outside to the driveway and have him/her practice the following steps:

1. Stop before entering the street.
2. Look left, right, and left again for traffic.
3. If there's no traffic, proceed into the roadway.

#### b. Running a Stop Sign

Car/Ebike crashes can happen when a cyclist runs a stop sign. Most cyclists who get hit riding through stop signs know that they were supposed to stop. They just thought it would be OK this time; or they may have been distracted. The thing to impress upon your child is that while he/she may not get hit every time, running stop signs will eventually result in an accident.



**What can you do?** Take your child to a stop sign near home. Explain what it means by emphasizing the following points:

1. Stop at all stop signs, regardless of what is happening.
2. Look in all directions for traffic.
3. Watch for oncoming cars making left turns.
4. Watch for cars behind you making right turns.
5. Wait for any cross traffic to clear.
6. Proceed when safe.

In order to make this lesson stick, you may have to change your own driving habits. If you creep through intersections controlled by stop signs, you are showing your child that you don't really believe what you preach. For your child's sake, stop at stop signs.

### c. Turning Without Warning (FIG 3)

Another major accident type involves cyclists who make unexpected left turns. They neither look behind for traffic, nor do they signal. The key factor here is neglecting to look to the rear. If the cyclist had looked, he/she would have seen the danger coming up from behind.

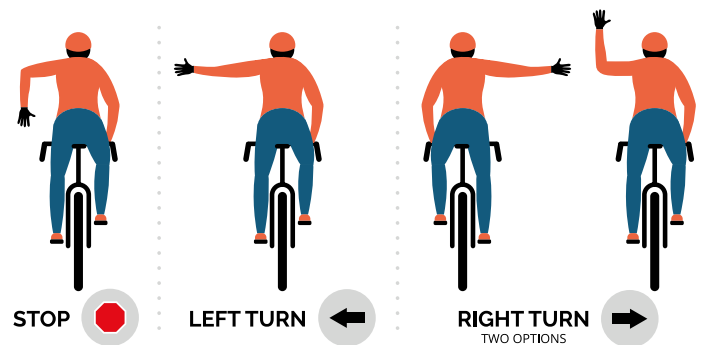

**What can you do?** Of course, you ought to teach your child not to ride across busy streets - at least until the child has had some advanced training and is old enough to understand traffic. But in the meantime, for residential street riding, you can teach your child to always look and signal before turning left. A big part of this lesson is teaching the child how to look to the rear without swerving.

Take your child to a playground or a safe area away from traffic or obstructions to practice riding along a straight line while looking behind. Stand alongside and hold up a different number of fingers on your hand after the child rides by. Call his/her name. After 15 minutes of practice, a ten-year-old should be able to look behind his/herself and identify how many fingers you are holding up - without swerving.

### d. Riding at Dawn, at Dusk or at Night (See also Section 2.E.).

Most car/Ebike accidents happen at night where an overtaking car hits a Ebike. (An overtaking car is one that comes up from behind and passes the cyclist on the left.) These overtaking accidents can be very serious.

**What can you do?** First, you should keep your youngster from riding at dawn, dusk or at night. It requires special skills and equipment. Few children have either. Secondly, make sure your child understands that if he/she gets caught out at dusk or after dark on a Ebike, the thing to do is to call you for a ride home. One suggestion is to have your child carry a cell phone, and as an added precaution, tape a phone number to the Ebike so that, in an emergency, an adult will be able to call home.

### **e. Following the Leader**

There is increased risk of car/Ebike collision if children are following each other, because if the first one does something dangerous, those following may do it too.

**What can you do?** Teach your child to always assess the traffic situation for him/herself. When a group is riding around, each cyclist should stop for stop signs; each cyclist should look to the rear before making left turns; and so on. One way to get the message across is to play a game with the child similar to 'Simon Says'. In this game, however, the emphasis should not be on doing what 'Simon Says', but rather have the child make a decision based on the situation. The child should learn to ignore what 'Simon Says'. Children need to learn to think for themselves to ride safely.

### **Summary**

Teach your child early - the earlier the better. Learning skills such as looking and avoiding hazards takes time. Be prepared to repeat lessons until your child understands what you're trying to get across. Be patient. Your efforts will be rewarded, knowing that your child is aware of safe riding skills.

**⚠ CAUTION: Your Ebike has speed enhancement through a motor, throttle, and additional Ebike components. See Section H. NOTE: added speed will increase need for added braking and awareness. Use of Ebike features is and can be a dangerous and is an increased risk for injury, serious injury or death. Know your bike and your own limitations and always wear a helmet and other appropriate safety gear and know your local laws and regulations.**

# APPENDIX B

## Intended use of your Ebike

In addition to The Basics (Section 2.A.), Riding Safely (Section 2.B.), Off Road Safety (Section 2.C.), Wet Weather Riding (Section 2.D.), Night Riding (Section 2.E.), and Downhill, Stunt and Competition Biking (Section 2.F. and Appendix B), kids need to be taught ... and to have frequently reinforced ... the following rules and lessons which adults are already expected to know. We urge you to take the time to familiarize yourself with these rules and to teach them to your child before you let your child ride unsupervised.

**⚠️ WARNING: Understand your Ebike and its intended use. Choosing the wrong Ebike for your purpose can be hazardous. Using your Ebike the wrong way is dangerous.**

No one type of Ebike is suited for all purposes. Your retailer can help you pick the “right tool for the job” and help you understand its limitations. There are many types of Ebikes and many variations within each type. There are many types of mountain, road, racing, hybrid, touring, cyclo-cross and tandem Ebikes.

There are also Ebikes that mix features. For example, there are road/racing Ebikes with triple cranks. These Ebikes have the low gearing of a touring Ebike, the quick handling of a racing Ebike, but are not well suited for carrying heavy loads on a tour. For that purpose, you want a touring Ebike.

Within each of type of Ebike, one can optimize for certain purposes. Visit your Ebike shop and find someone with expertise in the area that interests you. Do your own homework. Seemingly small changes such as the choice of tires can improve or diminish the performance of an Ebike for a certain purpose.

On the following pages, we generally outline the intended uses of various types of Ebikes.

Industry usage conditions are generalized and evolving. Consult **BIKE.com** at [cs@bike.com](mailto:cs@bike.com) or call at 1-(877)-755-2453(BIKE) or ask your local dealer for support.



## High-Performance Road

### CONDITION 1

Ebikes designed for riding on a paved surface where the tires do not lose ground contact.

#### INTENDED

To be ridden on paved roads only.

#### NOT INTENDED

For off-road, cyclo-cross, or touring with racks or panniers.

#### TRADE OFF

Material use is optimized to deliver both light weight and specific performance.

You must understand that (1) these types of Ebikes are intended to give an aggressive racer or competitive cyclist a performance advantage over a relatively short product life, (2) a less aggressive rider will enjoy longer frame life, (3) you are choosing light weight (shorter frame life) over more frame weight and a longer frame life, (4) you are choosing light weight over more dent resistant or rugged frames that weigh more. All frames that are very light need frequent inspection. These frames are likely to be damaged or broken in a crash. They are not designed to take abuse or be a rugged workhorse.

#### MAXIMUM WEIGHT LIMIT

RIDER	LUGGAGE*	TOTAL
<i>lbs / kg</i>	<i>lbs / kg</i>	<i>lbs / kg</i>
275 / 125	10 / 4.5	285 / 129

\* Seat Bag /Handlebar Bag Only



## General Purpose Riding CONDITION 2

Ebikes designed for riding Condition 1, plus smooth gravel roads and improved trails with moderate grades where the tires do not lose ground contact.

### INTENDED

For paved roads, gravel or dirt roads that are in good condition, and Ebike paths.

### NOT INTENDED

For off-road or mountain Ebike use, or for any kind of jumping. Some of these Ebikes have suspension features, but these features are designed to add comfort, not off-road capability. Some come with relatively wide tires that are well suited to gravel or dirt paths. Some come with relatively narrow tires that are best suited to faster riding on pavement. If you ride on gravel or dirt paths, carry heavier loads, or want more tire durability talk to your dealer about wider tires.

### MAXIMUM WEIGHT LIMIT

RIDER	LUGGAGE	TOTAL
<i>lbs / kg</i>	<i>lbs / kg</i>	<i>lbs / kg</i>
300 / 136	30 / 14	330 / 150
for Touring or Trekking		
300 / 136	55 / 25	355 / 161



## Cross-Country, Marathon, Hardtails

### CONDITION 3

Ebikes designed for riding Conditions 1 and 2, plus rough trails, small obstacles, and smooth technical areas, including areas where momentary loss of tire contact with the ground may occur. NOT jumping.

All mountain Ebikes without rear suspension are Condition 3, and so are some lightweight rear suspension models.

### INTENDED

For cross-country riding and racing which ranges from mild to aggressive over intermediate terrain (e.g., hilly with small obstacles like roots, rocks, loose surfaces and hard pack and depressions). Cross-country and marathon equipment (tires, shocks, frames, drive trains) are light weight, favoring nimble speed over brute force. Suspension travel is relatively short since the Ebike is intended to move quickly on the ground.

### NOT INTENDED

For Hardcore Freeriding, Extreme Downhill, Dirt Jumping, Slopestyle, or very aggressive or extreme riding. No spending time in the air landing hard and hammering through obstacles.

### TRADE OFF

Cross-Country Ebikes are lighter, faster to ride uphill, and more nimble than All-Mountain Ebikes. Cross-Country and Marathon Ebikes trade off some ruggedness for pedaling efficiency and uphill speed.(2) a less aggressive rider will enjoy longer frame life, (3) you are choosing light weight (shorter frame life) over more frame weight and a longer frame life, (4) you are choosing light weight over more dent resistant or rugged frames that weigh more. All frames that are very light need frequent inspection. These frames are likely to be damaged or broken in a crash. They are not designed to take abuse or be a rugged workhorse.

### MAXIMUM WEIGHT LIMIT

RIDER	LUGGAGE*	TOTAL
<i>lbs / kg</i>	<i>lbs / kg</i>	<i>lbs / kg</i>
300 / 136	5 / 2.3	305 / 138
* Seat Bag Only		
Front suspension frames manufactured with original equipment seat stay and dropout rack mounts only		
300 / 136	55 / 25	355 / 161



## All Mountain CONDITION 4

Ebikes designed for riding Conditions 1, 2, and 3, plus rough technical areas, moderately sized obstacles, and small jumps.

### INTENDED

For trail and uphill riding. All-Mountain Ebikes are: (1) more heavy duty than cross country Ebikes, but less heavy duty than Freeride Ebikes, (2) lighter and more nimble than Freeride Ebikes, (3) heavier and have more suspension travel than a cross country Ebike, allowing them to be ridden in more difficult terrain, over larger obstacles and moderate jumps, (4) intermediate in suspension travel and use components that fit the intermediate intended use, (5) cover a fairly wide range of intended use, and within this range are models that are more or less heavy duty. Talk to your retailer about your needs and these models.

### NOT INTENDED

For use in extreme forms of jumping/riding such as hardcore mountain, Freeriding, Downhill, North Shore, Dirt Jumping, Hucking etc. No large drop offs, jumps or launches (wooden structures, dirt embankments) requiring long suspension travel or heavy-duty components; and no spending time in the air landing hard and hammering through obstacles.

### TRADE OFF

All-Mountain Ebikes are more rugged than cross country Ebikes, for riding more difficult terrain. All-Mountain Ebikes are heavier and harder to ride uphill than cross country Ebikes. All-Mountain Ebikes are lighter, more nimble, and easier to ride uphill than Freeride Ebikes. All-Mountain Ebikes are not as rugged as Freeride Ebikes and must not be used for more extreme riding and terrain.

### MAXIMUM WEIGHT LIMIT

RIDER	LUGGAGE*	TOTAL
<i>lbs / kg</i>	<i>lbs / kg</i>	<i>lbs / kg</i>
300 / 136	5 / 2.3	305 / 138

\* Seat Bag Only



## Gravity, Freeride, and Downhill

### CONDITION 5

Ebikes designed for jumping, hucking, high speeds, or aggressive riding on rougher surfaces, or landing on flat surfaces. However, this type of riding is extremely hazardous and puts unpredictable forces on an Ebike which may overload the frame, fork, or parts. If you choose to ride in Condition 5 terrain, you should take appropriate safety precautions such as more frequent Ebike inspections and replacement of equipment. You should also wear comprehensive safety equipment such as a full-face helmet, pads, and body armor.

### INTENDED

For riding that includes the most difficult terrain that only very skilled riders should attempt. Gravity, Freeride, and Downhill are terms that describe hardcore mountain, north shore, slope-style. This is “extreme” riding and the terms describing it are constantly evolving.

Gravity, Freeride, and Downhill Ebikes are: (1) heavier and have more suspension travel than All-Mountain Ebikes, allowing them to be ridden in more difficult terrain, over larger obstacles, and larger jumps, (2) the longest in suspension travel and use components that fit heavy duty intended use. While all that is true, there is no guarantee that extreme riding will not break a Freeride Ebike.

The terrain and type of riding that Freeride Ebikes are designed for is inherently dangerous. Appropriate equipment, such as a Freeride Ebike, does not change this reality. In this kind of riding, bad judgment, bad luck, or riding beyond your capabilities can easily result in an accident, where you could be seriously injured, paralyzed or killed.

### NOT INTENDED

To be an excuse to try anything. Read Section 2. F.

### TRADE OFF

Freeride Ebikes are more rugged than All-Mountain Ebikes, for riding more difficult terrain. Freeride Ebikes are heavier and harder to ride uphill than All-Mountain Ebikes.

### MAXIMUM WEIGHT LIMIT

<b>RIDER</b>	<b>LUGGAGE*</b>	<b>TOTAL</b>
<i>lbs / kg</i>	<i>lbs / kg</i>	<i>lbs / kg</i>
300 / 136	5 / 2.3	305 / 138

\* Seat Bag Only





## **Dirt Jump CONDITION 5**

Ebikes designed for jumping, hucking, high speeds, or aggressive riding on rougher surfaces, or landing on flat surfaces. However, this type of riding is extremely hazardous and puts unpredictable forces on an Ebike which may overload the frame, fork, or parts. If you choose to ride in Condition 5 terrain, you should take appropriate safety precautions such as more frequent Ebike inspections and replacement of equipment. You should also wear comprehensive safety equipment such as a full-face helmet, pads, and body armor.

### **INTENDED**

For man-made dirt jumps, ramps, skate parks other predictable obstacles and terrain where riders need and use skill and Ebike control, rather than suspension. Dirt Jumping Ebikes are used much like heavy duty BMX Ebikes.

A Dirt Jumping Ebike does not give you skills to jump. Read Section 2. F.

### **NOT INTENDED**

For terrain, drop offs or landings where large amounts of suspension travel are needed to help absorb the shock of landing and help maintain control.

### **TRADE OFF**

Dirt Jumping Ebikes are lighter and more nimble than Freeride Ebikes, but they have no rear suspension and the suspension travel in the front is much shorter.

### **MAXIMUM WEIGHT LIMIT**

<b>RIDER</b>	<b>LUGGAGE</b>	<b>TOTAL</b>
<i>lbs / kg</i>	<i>lbs / kg</i>	<i>lbs / kg</i>
300 / 136	0	300 / 136

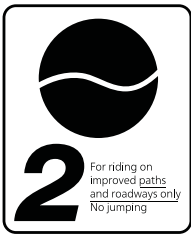

## **Cyclo-cross CONDITION 2**

Ebikes designed for riding Condition 1, plus smooth gravel roads and improved trails with moderate grades where the tires do not lose ground contact.

### **INTENDED**

For cyclo-cross riding, training, and racing. Cyclo-cross involves riding on a variety of terrain and surfaces including dirt or mud surfaces. Cyclo-cross Ebikes also work well for all weather rough road riding and commuting.

### **NOT INTENDED**

For off road or mountain Ebike use or jumping. Cyclo-cross riders and racers dismount before reaching an obstacle, carry their Ebike over the obstacle and then remount. Cyclo-cross Ebikes are not intended for mountain Ebike use. The relatively large road Ebike size wheels are faster and lighter than mountain Ebike wheels, but not as strong.

### **MAXIMUM WEIGHT LIMIT**

<b>RIDER</b>	<b>LUGGAGE</b>	<b>TOTAL</b>
<i>lbs / kg</i>	<i>lbs / kg</i>	<i>lbs / kg</i>
300 / 136	30 / 13.6	330 / 150



## Road Tandems

### CONDITION 1

Ebikes designed for riding on a paved surface where the tires do not lose ground contact.

#### INTENDED

Are designed to be ridden on paved roads only. They are not designed for mountain biking or off-road use.

#### NOT INTENDED

Road tandem should not be taken off-road or used as a mountain tandem.

#### MAXIMUM WEIGHT LIMIT

RIDER	LUGGAGE	TOTAL
<i>lbs / kg</i>	<i>lbs / kg</i>	<i>lbs / kg</i>
500 / 227	75 / 34	575 / 261

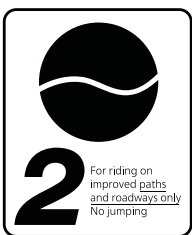

## Mountain Tandems

### CONDITION 2

Ebikes designed for riding Condition 1, plus smooth gravel roads and improved trails with moderate grades where the tires do not lose ground contact.

#### INTENDED

The challenges of mountain biking are obvious. The added challenges of tandem riding mean that you should limit off-road tandem riding to easy-moderate terrain.

#### NOT INTENDED

For very aggressive mountain Ebike riding. Mountain tandems are most definitely NOT for Downhill, Freeriding, North Shore. Choose terrain with the abilities of both the Tandem's captain and stoker in mind.

#### MAXIMUM WEIGHT LIMIT

RIDER	LUGGAGE	TOTAL
<i>lbs / kg</i>	<i>lbs / kg</i>	<i>lbs / kg</i>
500 / 227	75 / 34	575 / 261

# APPENDIX C

## The lifespan of your Ebike and its components

### 1. Nothing Lasts Forever, Including Your Ebike.

When the useful life of your Ebike or its components is over, continued use is hazardous. Every Ebike and its component parts have a finite, limited useful life. The length of that life will vary with the construction and materials used in the frame and components; the maintenance and care the frame and components receive over their life; and the type and amount of use to which the frame and components are subjected. Use in competitive events, trick riding, ramp riding, jumping, aggressive riding, riding on severe terrain, riding in severe climates, riding with heavy loads, commercial activities and other types of non-standard use can dramatically shorten the life of the frame and components. Any one or a combination of these conditions may result in an unpredictable failure.

All aspects of use being identical, lightweight Ebikes and their components will usually have a shorter life than heavier Ebikes and their components. In selecting a lightweight Ebike or components you are making a tradeoff, favoring the higher performance that comes with lighter weight over longevity. So, if you choose lightweight, high-performance equipment, be sure to have it inspected frequently.

You should have your Ebike, and its components checked periodically by your dealer for indicators of stress and/or potential failure, including cracks, deformation, corrosion, paint peeling, dents, and any other indicators of potential problems, inappropriate use or abuse. These are important safety checks and very important to help prevent accidents, bodily injury to the rider and shortened product life.

### 2. Perspective

Today's high-performance Ebikes require frequent and careful inspection and service. In this Appendix we try to explain some underlying material science basics and how they relate to your Ebike. We discuss some of the trade-offs made in designing your Ebike and what you can expect from your Ebike; and we provide important, basic guidelines on how to maintain and inspect it. We cannot teach you everything you need to know to properly inspect and service your Ebike; and that is why we repeatedly urge you to take your Ebike to your dealer for professional care and attention.

**⚠ WARNING: Frequent inspection of your Ebike is important to your safety. Follow the Mechanical Safety Check in Section 1.C of this Manual before every ride.**

**Periodic, more detailed inspection of your Ebike is important. How often this more detailed inspection is needed depends upon you.**

**You, the rider/owner, have control and knowledge of how often you use your Ebike, how hard you use it and where you use it. Because your dealer cannot track your use, you must take responsibility for periodically bringing your Ebike to your dealer for inspection and service. Your dealer will help you decide what frequency of inspection and service is appropriate for how and where you use your Ebike.**

**For your safety, understanding and communication with your dealer, we urge you to read this Appendix in its entirety. The materials used to make your Ebike determine how and how frequently to inspect.**

**Ignoring this WARNING can lead to frame, fork or other component failure, which can result in serious injury or death.**

## **A. Understanding metals**

Steel is the traditional material for building Ebike frames. It has good characteristics, but in high performance Ebikes, steel has been largely replaced by aluminum and some titanium. The main factor driving this change is interest in lighter Ebikes by cycling enthusiasts.

### **Properties of Metals**

Please understand that there is no simple statement that can be made that characterizes the use of different metals for Ebikes. What is true is how the metal chosen is applied is much more important than the material alone. One must look at the way the Ebike is designed, tested, manufactured, supported along with the characteristics of the metal rather than seeking a simplistic answer.

Metals vary widely in their resistance to corrosion. Steel must be protected, or rust will attack it. Aluminum and Titanium quickly develop an oxide film that protects the metal from further corrosion. Both are therefore quite resistant to corrosion. Aluminum is not perfectly corrosion resistant, and particular care must be used where it contacts other metals and galvanic corrosion can occur.

Metals are comparatively ductile. Ductile means bending, buckling, and stretching before breaking. Generally speaking, of the common Ebike frame building materials steel is the most ductile, titanium less ductile, followed by aluminum.

Metals vary in density. Density is weight per unit of material. Steel weighs 7.8 grams/cm<sup>3</sup> (grams per cubic centimeter), titanium 4.5 grams/cm<sup>3</sup>, aluminum 2.75 grams/cm<sup>3</sup>. Contrast these numbers with carbon fiber composite at 1.45 grams/cm<sup>3</sup>.

Metals are subject to fatigue. With enough cycles of use, at high enough loads, metals will eventually develop cracks that lead to failure. It is very important that you read the basics of metal fatigue below.

Let's say you hit a curb, ditch, rock, car, another cyclist, or other object. At any speed above a fast walk, your body will continue to move forward, momentum carrying you over the front of the Ebike. You cannot and will not stay on the Ebike, and what happens to the frame, fork and other components is irrelevant to what happens to your body.

What should you expect from your metal frame? It depends on many complex factors, which is why we tell you that crashworthiness cannot be a design criteria. With that important note, we can tell you that if the impact is hard enough the fork or frame may be bent or buckled. On a steel Ebike, the steel fork may be severely bent and the frame undamaged. Aluminum is less ductile than steel, but you can expect the fork and frame to be bent or buckled. Hit harder and the top tube may be broken in tension and the down tube buckled. Hit harder and the top tube may be broken, the down tube buckled and broken, leaving the head tube and fork separated from the main triangle. When a metal Ebike crashes, you will usually see some evidence of this ductility in bent, buckled, or folded metal.

It is now common for the main frame to be made of metal and the fork of carbon fiber. *See Section B, Understanding composites below.* The relative ductility of metals and the lack of ductility of carbon fiber means that in a crash scenario you can expect some bending or buckling in the metal but none in the carbon. Below some load the carbon fork may be intact even though the frame is damaged. Above some load the carbon fork will be completely broken.

### **The basics of metal fatigue**

Common sense tells us that nothing that is used lasts forever. The more you use something, and the harder you use it, and the worse the conditions you use it in, the shorter its life. Fatigue is the term used to describe accumulated damage to a part caused by repeated loading. To cause fatigue damage, the load the part receives must be great enough. A crude, often-used example is bending a paper clip back and forth (repeated loading) until it breaks. This simple definition will help you understand that fatigue has nothing to do with time or age. An Ebike in a garage does not fatigue. Fatigue happens only through use.

So, what kind of "damage" are we talking about? On a microscopic level, a crack forms in a highly stressed area. As the load is repeatedly applied, the crack grows. At some point the crack becomes visible to the naked eye. Eventually it becomes so large that the part is too weak to carry the load that it could carry without the crack. At that point there can be a complete and immediate failure of the part.

One can design a part that is so strong that fatigue life is nearly infinite. This requires a lot of material and a lot of weight. Any structure that must be light and strong will have a finite fatigue life. Aircraft, race cars, motorcycles all have parts with finite fatigue lives. If you wanted an Ebike with an infinite fatigue life, it would weigh far more than any Ebike sold today. So we all make a tradeoff: the wonderful, lightweight performance we want requires that we inspect the structure.

**What to look for**

<ul style="list-style-type: none"> <li>• <b>ONCE A CRACKS STARTS IT CAN GROW AND GROW FAST.</b> Think about the crack as forming a pathway to failure. This means that any crack is potentially dangerous and will only become more dangerous.</li> </ul>	<p><b>SIMPLE RULE 1:</b> If you find crack, replace the part.</p>
<ul style="list-style-type: none"> <li>• <b>CORROSION SPEEDS DAMAGE.</b> Cracks grow more quickly when they are in a corrosive environment. Think about the corrosive solution as further weakening and extending the crack.</li> </ul>	<p><b>SIMPLE RULE 2:</b> Clean your Ebike, lubricate your Ebike, protect your Ebike from salt, remove any salt as soon as you can.</p>
<ul style="list-style-type: none"> <li>• <b>SIGNIFICANT SCRATCHES, GOUGES, DENTS OR SCORING CREATE STARTING POINTS FOR CRACKS.</b> Think about the cut surface as a focal point for stress (in fact engineers call such areas “stress risers,” areas where the stress is increased). Perhaps you have seen glass cut? Recall how the glass was scored and then broke on the scored line.</li> </ul>	<p><b>SIMPLE RULE 4:</b> Do not scratch, gouge or score any surface. If you do, pay frequent attention to this area or replace the part.</p>
<ul style="list-style-type: none"> <li>• <b>SOME CRACKS (particularly larger ones) MAY MAKE CREAKING NOISE AS YOU RIDE.</b> Think about such a noise as a serious warning signal. Note that a well-maintained Ebike will be very quiet and free of creaks and squeaks.</li> </ul>	<p><b>SIMPLE RULE 5:</b> Investigate and find the source of any noise. It may not a be a crack, but whatever is causing the noise should be fixed promptly.</p>

## Fatigue Is Not A Perfectly Predictable Science

Fatigue is not a perfectly predictable science, but here are some general factors to help you and your dealer determine how often your Ebike should be inspected. The more you fit the “shorten product life” profile, the more frequent your need to inspect. The more you fit the “lengthen product life” profile, the less frequent your need to inspect.

### Factors that shorten product life:

- Hard, harsh riding style**
- “Hits”, crashes, jumps, other “shots” to the Ebike**
- High mileage**
- Higher body weight**
- Stronger, more fit, more aggressive rider**
- Corrosive environment (wet, salt air, winter road salt, accumulated sweat)**
- Presence of abrasive mud, dirt, sand, soil in riding environment**

### Factors that lengthen product life:

- Smooth, fluid riding style**
- No “hits”, crashes, jumps, other “shots” to the Ebike**
- Low mileage**
- Lower body weight**
- Less aggressive rider**
- Non-corrosive environment (dry, salt-free air)**
- Clean riding environment**

**⚠️ WARNING: Do not ride an Ebike or component with any crack, bulge, or dent, even a small one. Riding a cracked frame, fork or component could lead to complete failure, with risk of serious injury or death.**

## B. Understanding composites

All riders must understand a fundamental reality of composites. Composite materials constructed of carbon fibers are strong and light, but when crashed or overloaded, carbon fibers do not bend, they break.

### What Are Composites?

The term “composites” refers to the fact that a part or parts are made up of different components or materials. You’ve heard the term “carbon fiber Ebike.”

This really means “composite Ebike.”

Carbon fiber composites are typically a strong, light fiber in a matrix of plastic, molded to form a shape. Carbon composites are light relative to metals. Steel weighs 7.8 grams/cm<sup>3</sup> (grams per cubic centimeter), titanium 4.5 grams/cm<sup>3</sup>, aluminum 2.75 grams/cm<sup>3</sup>. Contrast these numbers with carbon fiber composite at 1.45 grams/cm<sup>3</sup>.

The composites with the best strength-to-weight ratios are made of carbon fiber in a matrix of epoxy plastic. The epoxy matrix bonds the carbon fibers together, transfers load to other fibers, and provides a smooth outer surface. The carbon fibers are the “skeleton” that carries the load.



## Why Are Composites Used?

Unlike metals, which have uniform properties in all directions (engineers call this isotropic), carbon fibers can be placed in specific orientations to optimize the structure for particular loads. The choice of where to place the carbon fibers gives engineers a powerful tool to create strong, light Ebikes. Engineers may also orient fibers to suit other goals such as comfort and vibration damping.

Carbon fiber composites are very corrosion resistant, much more so than most metals. Think about carbon fiber or fiberglass boats.

Carbon fiber materials have a very high strength-to-weight ratio.

## What Are the Limits Of Composites?

Well designed “composite” or carbon fiber Ebikes and components have long fatigue lives, usually better than their metal equivalents.

While fatigue life is an advantage of carbon fiber, you must still regularly inspect your carbon fiber frame, fork, or components.

Carbon fiber composites are not ductile. Once a carbon structure is overloaded, it will not bend; it will break. At and near the break, there will be rough, sharp edges and maybe delamination of carbon fiber or carbon fiber fabric layers. There will be no bending, buckling, or stretching.

## If You Hit Something or Have A Crash,

### What Can You Expect From Your Carbon Fiber Ebike?

Let's say you hit a curb, ditch, rock, car, other cyclist, or other object. At any speed above a fast walk, your body will continue to move forward, the momentum carrying you over the front of the Ebike. You cannot and will not stay on the Ebike and what happens to the frame, fork and other components is irrelevant to what happens to your body.

**What should you expect from your carbon frame?** It depends on many complex factors. But we can tell you that if the impact is hard enough, the fork or frame may be completely broken. Note the significant difference in behavior between carbon and metal in this Appendix. Even if the carbon frame was twice as strong as a metal frame, once the carbon frame is overloaded it will not bend, it will break completely.

**⚠️ WARNING: Be aware that high temperature in a confined environment can affect the integrity of composite materials, resulting in component failure which could cause you to lose control and fall.**

## Inspection of Composite Frame, Fork, and Components

### Cracks:

Inspect for cracks, broken, or splintered areas. Any crack is serious. Do not ride any Ebike or component that has a crack of any size.

### Delamination:

Delamination is serious damage. Composites are made from layers of fabric. Delamination means that the layers of fabric are no longer bonded together. Do not ride any Ebike or component that has any delamination.

These are some delamination clues:

1. A cloudy or white area. This kind of area looks different from the ordinary undamaged areas. Undamaged areas will look glassy, shiny, or “deep,” as if one was looking into a clear liquid. Delaminated areas will look opaque and cloudy.
2. Bulging or deformed shape. If delamination occurs, the surface shape may change. The surface may have a bump, a bulge, soft spot, or not be smooth and fair.
3. A difference in sound when tapping the surface. If you gently tap the surface of an undamaged composite, you will hear a consistent sound, usually a hard, sharp sound. If you then tap a delaminated area, you will hear a different sound, usually duller, less sharp.

### Unusual Noises:

Either a crack or delamination can cause creaking noises while riding. Think about such a noise as a serious warning signal. A well-maintained Ebike will be very quiet and free of creaks and squeaks. Investigate and find the source of any noise. It may not be a crack or delamination, but whatever is causing the noise must be fixed or replaced before riding.

**⚠ WARNING: Do not ride an Ebike or component with any delamination or crack. Riding a delaminated or cracked frame, fork or other component could lead to complete failure, with risk of serious injury or death.**

### **C. Understanding components**

It is often necessary to remove and disassemble components in order to properly and carefully inspect them. This is a job for a professional Ebike mechanic with the special tools, skills, and experience to inspect and service today's high-tech high-performance Ebikes and their components.

#### **Aftermarket "Super Light" components**

Think carefully about your rider profile as outlined above. The more you fit the "shorten product life" profile, the more you must question the use of super light components. The more you fit the "lengthen product life" profile, the more likely it is that lighter components may be suitable for you. Discuss your needs and your profile very honestly with your dealer.

Take these choices seriously and understand that you are responsible for the changes.

A useful slogan to discuss with your dealer if you contemplate changing components is "Strong, Light, Cheap –pick two."

#### **Original Equipment components**

Ebike and component manufacturers test the fatigue life of the components that are original equipment on your Ebike. This means that they have met test criteria and have reasonable fatigue life. It does not mean that the original components will last forever.

They won't, and provides a smooth outer surface. The carbon fibers are the "skeleton" that carries the load.

# APPENDIX D

## Fastener Torque Specifications

Correct tightening torque of threaded fasteners is very important to your safety. Always tighten fasteners to the correct torque. In case of a conflict between the instructions in this manual and information provided by a component manufacturer, consult with your dealer or the manufacturer's customer service representative for clarification. Bolts that are too tight can stretch and deform. Bolts that are too loose can move and fatigue. Either mistake can lead to a sudden failure of the bolt.

Always use a correctly calibrated torque wrench to tighten critical fasteners on your Ebike. Carefully follow the torque wrench manufacturer's instructions on the correct way to set and use the torque wrench for accurate results.

### FASTENER RECOMMENDED TORQUE

The below spec if for DENAGO eBike specifically	Model <b>CITY 1.0</b>	issued 02/01/2022	
<i>All figures in the table below are available in Newton Meters (NM), Inch-Pound (IN-LB) and Foot-Pounds (FT-LBS). Note that some companies do not specify torque for certain components or parts thus we offer a range. Contact the manufacturer for the most up to date specifications.</i>			
<b>Headset - Handlebar SPEC</b>			
Component	Torque Spec Newton Meters (NM)	Torque Spec Inch-Pound (IN-LB)	Torque Spec Foot-Pounds (FT-LBS)
Stem - Binder Bolt(s) to steer tube (Threadless)	6.215	55	4.58
Stem - Binder Bolt(s) to Handlebar	10	88.5	7.375
Stem - Binder Bolt(s) Threadless Compression Bolt	3.955	35	2.92
Stem - Binder Bolt(s) to Internal Steer Tube/Fork (QUILL STYLE)	19.66-29.38	174-260	14.5-21.66
Grips with Locking Mechanism	-	-	0
Shift Lever to Handlebar (Clamp)	5.98-7.91	53-70	4.42-5.83
Brake lever - MTB type	5.98-7.91	53-70	4.42-5.83
Bell to Handlebar (clamp)	1.92	17	1.416666667
Monitor to Handlebar (clamp)	1.02	9	0.75
Throttle to Handlebar (clamp)	1.92	17	1.416666667

<b>Seat - Seat Post SPEC</b>			
<b>Component</b>	<b>Torque Spec Newton Meters (NM)</b>	<b>Torque Spec Inch-Pound (IN-LB)</b>	<b>Torque Spec Foot-Pounds (FT-LBS)</b>
<b>Seat Rail to Seat Post</b>	19.66-39.21	174-347	14.5-28.92
<b>Seat Post Binder (IF BOLT)</b>	seat post requires only minimal tightening to not slide downward. Avoid over tightening	seat post requires only minimal tightening to not slide downward. Avoid over tightening	seat post requires only minimal tightening to not slide downward. Avoid over tightening
<b>Quick release Seat Post</b>	Measured torque not typically used. Common industry practice is resistance at lever halfway through swing from open to fully closed.	Measured torque not typically used. Common industry practice is resistance at lever halfway through swing from open to fully closed.	Measured torque not typically used. Common industry practice is resistance at lever halfway through swing from open to fully closed.

<b>Crankset - Bottom Bracket - Pedal SPEC</b>			
<b>Component</b>	<b>Torque Spec Newton Meters (NM)</b>	<b>Torque Spec Inch-Pound (IN-LB)</b>	<b>Torque Spec Foot-Pounds (FT-LBS)</b>
<b>Pedal into crank</b>	16.95	150	12.5
<b>Crank bolt (including spline - type cranks and square spindle cranks)</b>	34.46-44.18	305-391	25.42-32.58
<b>Chainring bolt - steel</b>	7.91-10.73	70.95	5.83-7.92
<b>Chainring bolt - aluminum</b>	4.97-9.94	44-88	3.67-7.33

<b>Derailleur - Shift SPEC</b>			
<b>Component</b>	<b>Torque Spec Newton Meters (NM)</b>	<b>Torque Spec Inch-Pound (IN-LB)</b>	<b>Torque Spec Foot-Pounds (FT-LBS)</b>
<b>Rear derailleur mounting bolt</b>	7.91-9.72	70-86	5.83-7.18
<b>Rear derailleur cable inch bolt</b>	3.96	35	2.916666667
<b>Rear derailleur pulley wheel</b>	3.05-3.84	27-34	2.25-2.83
<b>Front derailleur clamp mount</b>	4.97-6.78	44-60	3.67-5
<b>Front derailleur cable pinch</b>	4.97-6.78	44-60	3.67-5

### Wheel - Hub - Rear Cog SPEC

Component	Torque Spec Newton Meters (NM)	Torque Spec Inch-Pound (IN-LB)	Torque Spec Foot-Pounds (FT-LBS)
<b>Quick release at wheel</b>	Measured torque not typically used. Common industry practice is resistance at lever halfway through swing from open to fully closed,	Measured torque not typically used. Common industry practice is resistance at lever halfway through swing from open to fully closed,	Measured torque not typically used. Common industry practice is resistance at lever halfway through swing from open to fully closed,
<b>Wheel axle nuts to frame</b>	22.6-25.42	200-225	16.67-18.75
<b>Cassette sprocket lockring</b>	29.38-49.04	260-434	21.67-36.17
<b>Hub cone locking nut</b>	9.83-24.52	87-217	7.25-18.08
<b>Freehub body</b>	34.46-49.04	305-434	25.42-36.17

### Disc Brake System SPEC

Component	Torque Spec Newton Meters (NM)	Torque Spec Inch-Pound (IN-LB)	Torque Spec Foot-Pounds (FT-LBS)
<b>Disc rotor to hub</b>	2.04-3.96	18-35	1.5-2.92
<b>Caliper mount</b>	5.99-7.8	53-69	4.42-5.75
<b>Hydraulic hose fittings</b>	4.97-9.94	44-60	3.66-5

### E-Bike Component SPEC

Component	Torque Spec Newton Meters (NM)	Torque Spec Inch-Pound (IN-LB)	Torque Spec Foot-Pounds (FT-LBS)

Please contact BIKE.com at [cs@bike.com](mailto:cs@bike.com) or call at 1-(877)-755-2453(BIKE) or ask your dealer for service instructions if you are uncertain or have the slightest doubt.

# APPENDIX E

## Trouble Shooting - Some common issues

	Symptoms	Possible Causes	Most Common Solutions
1	The bike does not work	<ul style="list-style-type: none"> <li>• Insufficient battery power</li> <li>• Faulty connections</li> <li>• Battery not full seated in tray</li> <li>• Improper turn on sequence</li> <li>• Brakes are applied</li> </ul>	<ul style="list-style-type: none"> <li>• Charge the battery</li> <li>• Clean and reseat connectors</li> <li>• Install battery correctly</li> <li>• Turn on bike with proper sequence</li> <li>• Disengage brakes</li> </ul>
2	Reduced range	<ul style="list-style-type: none"> <li>• Low tire pressure</li> <li>• Low or faulty battery</li> <li>• Driving with too many hills, headwind, braking and/or excessive load</li> <li>• Battery discharged for long period of time without regular charges, aged, damaged or unbalanced</li> <li>• Brakes rubbing</li> </ul>	<ul style="list-style-type: none"> <li>• Adjust tire pressure</li> <li>• Check connections or charge battery</li> <li>• Assist with pedals or adjust route</li> <li>• Balance the battery; contact Product Support if range decline persists</li> <li>• Adjust the brakes</li> </ul>
3	The battery will not charge	<ul style="list-style-type: none"> <li>• Charge not well connected</li> <li>• Charger damaged</li> <li>• Battery damaged</li> <li>• Wiring damaged</li> <li>• Blown charge fuse</li> </ul>	<ul style="list-style-type: none"> <li>• Adjust the connections</li> <li>• Replace</li> <li>• Replace</li> <li>• Repair or replace</li> <li>• Replace charge fuse</li> </ul>
4	Irregular acceleration and/or reduced top speed	<ul style="list-style-type: none"> <li>• Insufficient battery power</li> <li>• Loose or damaged throttle</li> <li>• Misaligned or damaged magnet ring</li> </ul>	<ul style="list-style-type: none"> <li>• Charge or replace battery</li> <li>• Replace throttle</li> <li>• Align or replace magnet ring</li> </ul>
5	The motor does not respond with the bike is powered on	<ul style="list-style-type: none"> <li>• Loose wiring</li> <li>• Loose or damaged throttle</li> <li>• Loose or damaged motor plug wire</li> <li>• Damaged motor</li> </ul>	<ul style="list-style-type: none"> <li>• Repair and or reconnect</li> <li>• Tighten or replace</li> <li>• Secure or replace</li> <li>• Repair or replace</li> </ul>
6	Wheel or motor makes strange noises	<ul style="list-style-type: none"> <li>• Loose or damaged wheel spokes or rim</li> <li>• Loose or damaged motor wiring</li> </ul>	<ul style="list-style-type: none"> <li>• Tighten, repair or replace</li> <li>• Reconnect or replace motor</li> </ul>

Please contact BIKE.com at [cs@bike.com](mailto:cs@bike.com) or call at 1-(877)-755-2453(BIKE) or ask your dealer for service instructions if you are uncertain or have the slightest doubt.

# APPENDIX F

## Trouble Shooting - Monitor

Denago's City 1.0 E09 step-over and E10 step-thru models are design to provide reliable performance for a lifetime of use. In the rare event of a problem, an error code will be shown on the display to help diagnose and resolve the issue.

Code	Name	Cause	Solution
21	Current Abnormal	Possible damage to the motor cable.	Check whether the three phase wires of the motor are short-circuited.
22	Throttle Abnormal	The thumb throttle is not returning to its original position when released.	Make sure nothing is blocking the throttle lever from moving through the full range of motion in both directions.
23	Motor Phase Problem	Poor condition phase wires, or disconnected motor phase line.	Visually inspect the cables connecting the rear hub motor to the controller for damage. Disconnect the hub motor cable, inspect for and remove any debris or contamination, and firmly re-connect the cable.
24	Motor Hall Defect	No Hall controller: check whether the phase wire is in good condition. With Hall controller: check whether the Hall outlet is good.	This error may appear if the connection to the rear wheel hub motor is not fully plugged in. Unplug it, check for and remove any debris, then fully re-connect.
25	Brake Failed	The eBike motor cut-off brake levers are engaged, which stops the motor from turning on.	When you power on the eBike, make sure you aren't squeezing the brake lever(s). Check the sensitivity adjustment of the brake lever motor cut-off switches.
30	Communication Failure	The display cannot communicate with the controller.	Check to make sure the connection between the display and controller is fully engaged and free of debris.

Please contact BIKE.com at [cs@bike.com](mailto:cs@bike.com) or call at 1-(877)-755-2453(BIKE) or ask your dealer for service instructions if you are uncertain or have the slightest doubt.



## Getting Ready for your First Ride and Each Future Ride

1. Confirm you battery is fully charged and installed correctly.
  - a. Your monitor will not turn on if you are charging your battery  
To Turn on the Monitor Press the M button on the HMI.
  - b. The key is only to secure and remove the battery. It is not an ON/OFF key.

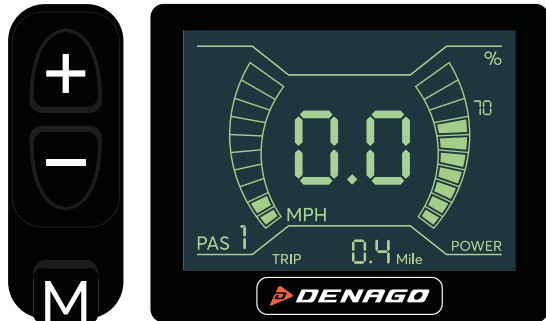

2. Check you tire pressure
3. Check your wheels are secure and mounted correctly
4. Check you brakes for function
5. Check your wheels to insure true
6. Go thru and check all bolts for being tight and secure.

### Your Ready to Go

Always wear a helmet and be safe

Standing over the bike you have the **HMI** (Human Machine Interface) controller on the left side. It has **+** - and **M** button

Press the **M** button until the monitor/display turns on.

Check the PAS setting - Ideally you want to start in **PAS0** or **PAS1**.

See Speed Adjustment to help find your most comfortable setting.

**YOU ARE READY to RIDE. ENJOY!**

**Contact US at**  
**BIKE USA, Inc dba BIKE.com**  
**PO BOX 631513**  
**Irving, Texas 75063**  
**www.BIKE.com**  
**Customer Service cs@BIKE.com**  
**Phone 1(877)-755-(BIKE)2453**